



## touchMATRIX<sup>®</sup> Indicator AX350

Process indicator with two 16 bit analog inputs, touch screen and graphic display

### Product Features:

- Operating modes for visualization of input 1, input 2 or combinations of inputs (1+2, 1-2, 1x2, 1:2)
- Two universal 16 bit analog inputs for -10 ... +10 V / 0 ... 10 V / 0 ... 20 mA / 4 ... 20 mA
- High accuracy reference output 10 V for potentiometers > 1 kOhm
- Bright and high-contrast display with event-dependent color variations
- Emulation of a 7-segment display inclusively icons and units
- Intuitive and easy parameterization by plain text and touchscreen
- 24 V auxiliary output for encoder supply
- Totalization for each input
- Linearization with 24 control points for each input
- Numerous features, e. g. tara, averaging filter, sampling time for each input
- 3.78 x 1.89 inch norm panel housing and IP65 protection

### Available Options:

**AX350:** Basic unit with 2 analog inputs (16 Bit), 3 control inputs

- Option **AC:** Power supply 115...230 VAC
- Option **AO:** 16 bit analog output, 4 control outputs, serial RS232 interface
- Option **AR:** 16 bit analog output, 4 control outputs, serial RS485 interface
- Option **CO:** 4 control outputs, serial RS232 interface
- Option **CR:** 4 control outputs, serial RS485 interface
- Option **RL:** 2 relay outputs
- Option **IO:** IO-Link Device V1.1

Options can be combined

Die deutsche Beschreibung ist verfügbar unter:  
[https://www.motrona.com/fileadmin/files/bedienungsanleitungen/Ax350\\_d.pdf](https://www.motrona.com/fileadmin/files/bedienungsanleitungen/Ax350_d.pdf)



The English description is available at:  
[https://www.motrona.com/fileadmin/files/bedienungsanleitungen/Ax350\\_e.pdf](https://www.motrona.com/fileadmin/files/bedienungsanleitungen/Ax350_e.pdf)



La description en français est disponible sur:  
[https://www.motrona.com/fileadmin/files/bedienungsanleitungen/Ax350\\_f.pdf](https://www.motrona.com/fileadmin/files/bedienungsanleitungen/Ax350_f.pdf)



Version:	Description
AX350_01a_oi/cn/Jan-17	First Version
AX350_02a_oi/cn/Feb-17	Second Version
AX350_02b_oi/cn/March-17	minor changes and fixes
AX350_02c_oi/cn/Jul-17	minor changes and fixes
AX350_3a_oi/cn/Okt-17	Expansion of the scale units
AX350_4a_oi/sn/April-18	Extension with IO-link
AX350_5a_oi/cn/June-18	Extension with Modbus
AX350_5b_oi/cn/July-18	With Modbus and IO-Link description
AX350_6a_oi/tgo/March-19	Extension of large display
AX350_6b_oi/mbo/Aug-19	Extension of QR-code

Legal notices:
All contents included in this manual are protected by the terms of use and copyrights of motrona GmbH. Any reproduction, modification, usage or publication in other electronic and printed media as well as in the internet requires prior written authorization by motrona GmbH.

# Table of Contents

<b>1.</b>	<b>Safety Instructions and Responsibility.....</b>	<b>4</b>
1.1.	General Safety Instructions .....	4
1.2.	Use according to the intended purpose .....	5
1.3.	Installation .....	6
1.4.	Cleaning, Maintenance and Service Notes.....	6
<b>2.</b>	<b>Introduction.....</b>	<b>7</b>
2.1.	Operation mode .....	7
<b>3.</b>	<b>Electrical Connections.....</b>	<b>9</b>
3.1.	DC Power Supply .....	9
3.2.	Auxiliary Voltage Output.....	9
3.3.	Analog Input.....	10
3.4.	Reference-output .....	10
3.5.	Control Inputs.....	11
3.6.	Analog Output (Option AO/AR).....	11
3.7.	Serial interface (Option AO/AR/CO/CR).....	12
3.8.	Control-Output (Option AO/AR/CO/CR).....	12
3.9.	AC Power supply (Option AC) .....	13
3.10.	Relay-Output (Option RL) .....	13
3.11.	IO-Link (Option IO).....	14
<b>4.</b>	<b>Operation and touch screen .....</b>	<b>15</b>
4.1.	Screen structure for parametrization .....	15
4.2.	Screen structure in operation .....	16
4.3.	Error messages .....	17
<b>5.</b>	<b>Parameter / Overview-Menu Structure.....</b>	<b>20</b>
5.1.	General Menu .....	22
5.2.	IN 1 Properties .....	23
5.3.	IN 1 Linearization.....	25
5.4.	IN 1 Totalization.....	26
5.5.	IN 2 Properties .....	27
5.6.	IN 2 Linearization.....	28
5.7.	IN 2 Totalization.....	28
5.8.	Linkage Properties .....	29
5.9.	IO-Link Properties.....	30
5.10.	Preselection Values .....	31
5.11.	Preselection 1 Menu.....	31
5.12.	Preselection 2 Menu.....	34
5.13.	Preselection 3 Menu.....	35
5.14.	Preselection 4 Menu.....	36
5.15.	Serial Menu .....	37
5.16.	Analog Out Menu.....	39
5.17.	Command Menu.....	41
5.18.	Display Menu.....	42
<b>6.</b>	<b>Appendix.....</b>	<b>46</b>
6.1.	Data readout via serial interface.....	46
6.2.	Modbus RTU Interface.....	47

6.2.1.	Parameter setting .....	47
6.2.2.	Modbus Communication.....	48
6.2.3.	Diagnostics .....	50
6.3.	IO-Link Modul.....	50
6.3.1.	Communications data.....	50
6.3.2.	Features .....	50
6.3.3.	IO-Link interface.....	50
6.3.4.	Parameter data .....	52
6.3.5.	System Commands .....	60
6.3.6.	Application specific commands.....	61
6.3.7.	IO-Link Prozessdaten .....	62
6.3.8.	Error type.....	64
6.4.	Declaration of Conformity IO-Link module .....	65
6.5.	Display of scale units.....	66
6.6.	Parameter / serial codes.....	67
6.7.	Linearization.....	74
6.8.	Dimensions .....	76
6.9.	Technical specifications .....	77

# 1. Safety Instructions and Responsibility

## 1.1. General Safety Instructions

This operation manual is a significant component of the unit and includes important rules and hints about the installation, function and usage. Non-observance can result in damage and/or impairment of the functions to the unit or the machine or even in injury to persons using the equipment!

**Please read the following instructions carefully before operating the device and observe all safety and warning instructions! Keep the manual for later use.**

A pertinent qualification of the respective staff is a fundamental requirement in order to use these manual. The unit must be installed, connected and put into operation by a qualified electrician.

**Liability exclusion:** The manufacturer is not liable for personal injury and/or damage to property and for consequential damage, due to incorrect handling, installation and operation. Further claims, due to errors in the operation manual as well as misinterpretations are excluded from liability.

In addition the manufacturer reserves the right to modify the hardware, software or operation manual at any time and without prior notice. Therefore, there might be minor differences between the unit and the descriptions in operation manual.

The raiser respectively positioner is exclusively responsible for the safety of the system and equipment where the unit will be integrated.

During installation or maintenance all general and also all country- and application-specific safety rules and standards must be observed.

If the device is used in processes, where a failure or faulty operation could damage the system or injure persons, appropriate precautions to avoid such consequences must be taken.

## 1.2. Use according to the intended purpose

The unit is intended exclusively for use in industrial machines, constructions and systems. Non-conforming usage does not correspond to the provisions and lies within the sole responsibility of the user. The manufacturer is not liable for damages which have arisen through unsuitable and improper use.

Please note that device may only be installed in proper form and used in a technically perfect condition (in accordance to the Technical Specifications). The device is not suitable for operation in explosion-proof areas or areas which are excluded by the EN 61010-1 standard.

### 1.3. Installation

The device is only allowed to be installed and operated within the permissible temperature range. Please ensure an adequate ventilation and avoid all direct contact between the device and hot or aggressive gases and liquids.

Before installation or maintenance, the unit must be disconnected from all voltage-sources. Further it must be ensured that no danger can arise by touching the disconnected voltage-sources.

Devices which are supplied by AC-voltages must be connected exclusively by switches, respectively circuit-breakers with the low voltage network. The switch or circuit-breaker must be placed as near as possible to the device and further indicated as separator.

Incoming as well as outgoing wires and wires for extra low voltages (ELV) must be separated from dangerous electrical cables (SELV circuits) by using a double resp. increased isolation.

All selected wires and isolations must be conform to the provided voltage- and temperature-ranges. Further all country- and application-specific standards, which are relevant for structure, form and quality of the wires, must be ensured. Indications about the permissible wire cross-sections for wiring are described in the Technical Specifications.

Before first start-up it must be ensured that all connections and wires are firmly seated and secured in the screw terminals. All (inclusively unused) terminals must be fastened by turning the relevant screws clockwise up to the stop.

Overvoltages at the connections must be limited to values in accordance to the overvoltage category II.

**For placement, wiring, environmental conditions as well as shielding and earthing/grounding of the supply lines the general standards of industrial automation industry and the specific shielding instructions of the manufacturer are valid.** Please find all respective hints and rules on <https://www.motrona.com/en/support> --> “[General EMC Rules for Wiring, Screening and Earthing]”.

### 1.4. Cleaning, Maintenance and Service Notes

To clean the front of the unit please use only a slightly damp (not wet!), soft cloth. For the rear no cleaning is necessary. For an unscheduled, individual cleaning of the rear the maintenance staff or assembler is self-responsible.

During normal operation no maintenance is necessary. In case of unexpected problems, failures or malfunctions the device must be shipped for back to the manufacturer for checking, adjustment and reparation (if necessary). Unauthorized opening and repairing can have negative effects or failures to the protection-measures of the unit.

## 2. Introduction

This series of display unit is suitable for analog signals (-10 ... 10V or 0/4 ... 20 mA). It is very versatile in use, due to the intuitive handling and the extensive range of functions and options.

### 2.1. Operation mode

All functions are can be configured in the parameter menu.

The device can be set to one of the following operation modes:

- SINGLE:  
single-channel operation of input 1
- DUAL:  
two-channel operation of input 1 and 2
- IN 1 + IN 2:  
two-channel operation of input 1 and 2 in combination with sum
- IN1 – IN 2:  
two-channel operation of input 1 and 2 in combination with difference.
- IN 1 x IN 2:  
two-channel operation of input 1 and 2 in combination with multiplication
- IN 1 / IN 2:  
two-channel operation of input 1 and 2 in combination with division .

# Function diagram

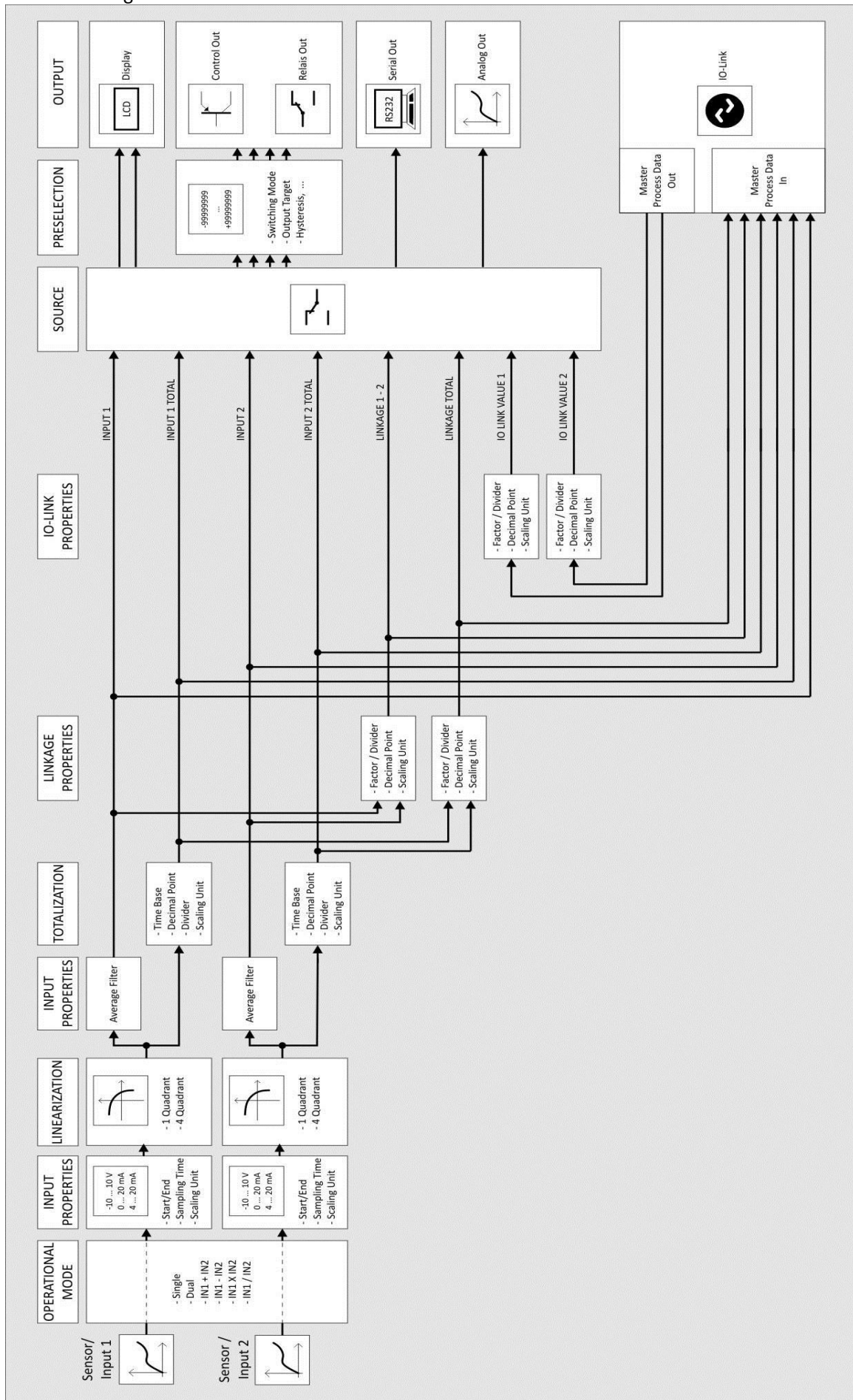



# 3. Electrical Connections

The terminal screws should be tightened with a slotted screwdriver (blade width 2mm).

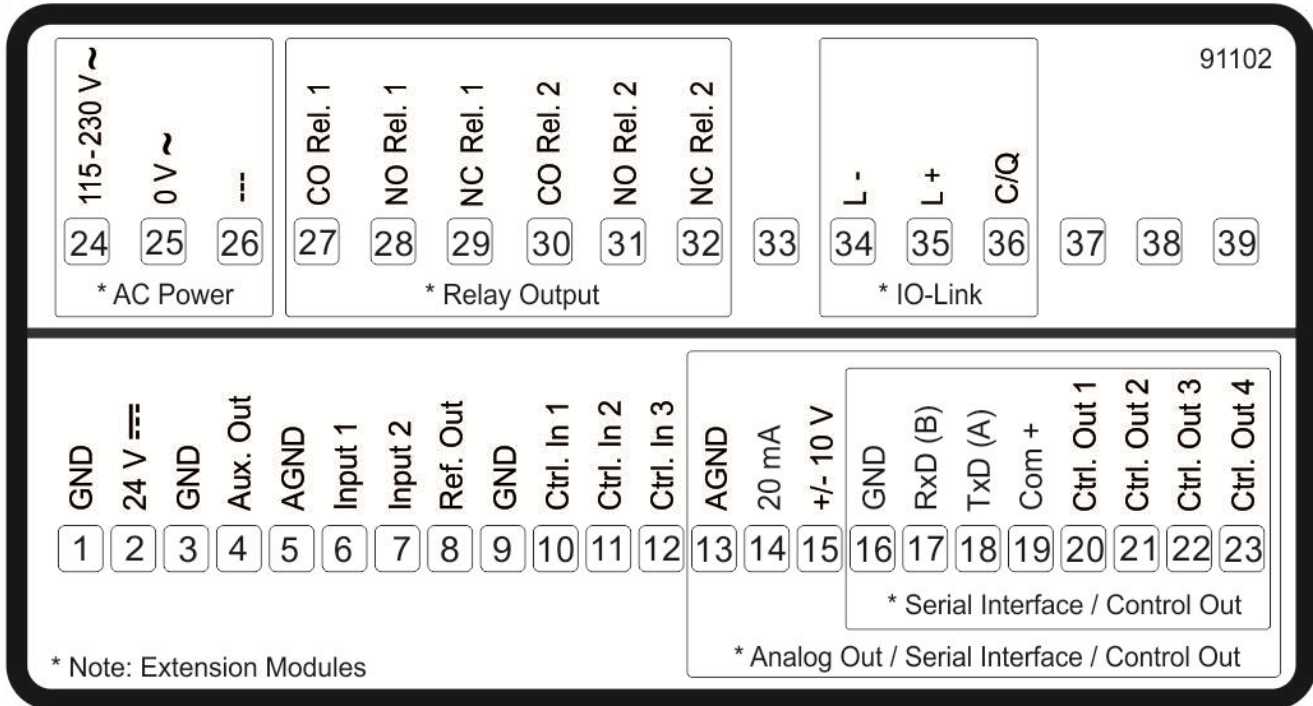

## 3.1. DC Power Supply

The unit accepts DC supply from 18 to 30 V at the terminals 1 and 2. The power consumption depends on the level of the supply voltage with aprox. 100 mA and the additional current required at the auxiliary voltage output.

All GND terminals are internally interconnected.

## 3.2. Auxiliary Voltage Output

Terminal 3 and 4 provide an auxiliary output for supply of sensors and encoders.

The output voltage depends on the power supply.

DC version	AC version
The encoder voltage is approx. 1 V lower than the power supply voltage at terminal 1 and 2 and should be loaded with max. 250 mA.	The encoder voltage is 24 VDC ( $\pm 15\%$ ) and should be loaded with max. 150 mA up to 45 degrees Celsius. At higher temperature the maximum output current is reduced to 80 mA.

### 3.3. Analog Input

The reference potential (AGND) for the analog inputs is connected at terminal 5. The unit provides two 16 bit analog inputs at terminal 6 and 7. The characteristics of the analog inputs (voltage input or current input ) can be set in the Menu IN 1/IN 2 PROPERTIES.



**Important:**  
Before connecting the sensor the configuration (voltage or current input) must be set!

Wiring of the incremental inputs:

#### Voltage input

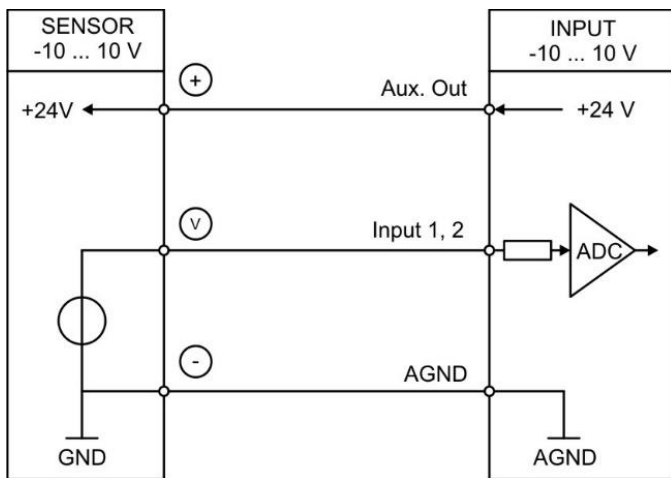

#### Current input

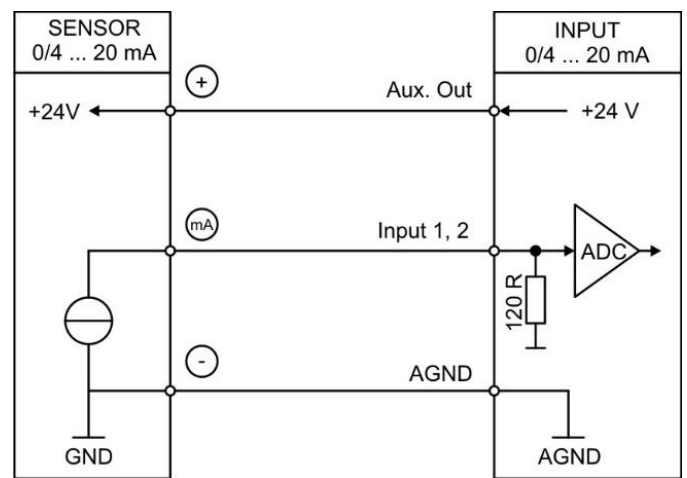

### 3.4. Reference-output

The unit provides a 10 V reference-output at terminal 8. This output should be loaded with 10 mA maximum. This reference-output can be used for connecting a potentiometer.

Referenz output with potentiometer:

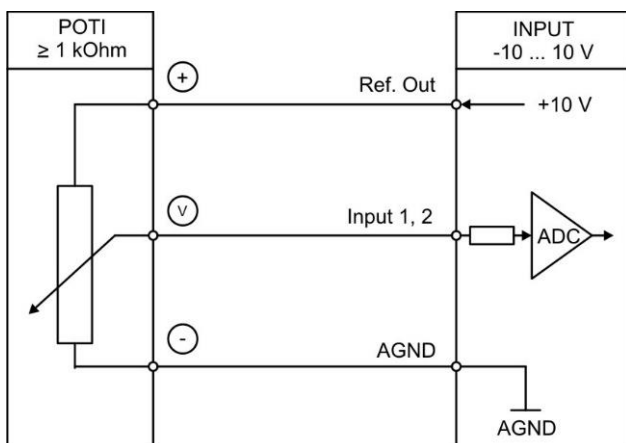

### 3.5. Control Inputs

The three control inputs at terminal 10, 11 and 12 have HTL PNP characteristics.

In the COMMAND MENU the programmable functions for the control inputs can be assigned. Available functions are: reset the display value, display switching, locking the touch screen or release the lock function of the control or relay outputs.

Wiring of the control inputs:

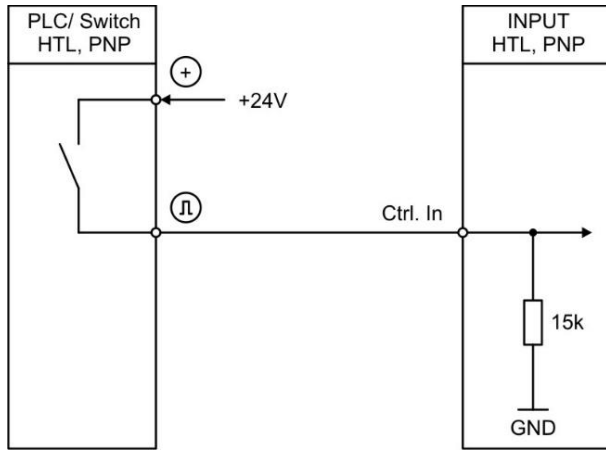

Unconnected control inputs are always “LOW”.

All inputs are designed to receive impulses from an electronic impulse source.

#### Notice for mechanical switching contacts:

When exceptionally mechanical contacts are used, please connect an external capacitor between GND (-) and the corresponding input (+). A capacity of 10  $\mu$ F will reduce the input frequency to 20 Hz and miscounting due to contact bouncing will be eliminated.

### 3.6. Analog Output (Option AO/AR)

A 16 bit analog output is available at terminal 13 and 14 / 15.

This output can be configured and scaled in the ANALOG MENU.

The following configuration is possible:

- Voltage output: -10 ... +10 V
- Current output: 0 ... 20 mA
- Current output: 4 ... 20 mA

The analog output is proportional to the the reference source and is referenced to potential AGND. AGND and GND are internally interconnected.



**Important:**

**A parallel operation with voltage and current output at the analog output is not allowed.**

### 3.7. Serial interface (Option AO/AR/CO/CR)

A serial interface (RS232 or RS485) is available at terminal 16, 17 und 18. This interface can be configured in the SERIAL MENU.

The serial interface RS232 or RS485 can be used:

- for easy setup and commissioning of the units
- to modify settings and parameters during operation
- to read out internal states and actual measuring values by PC or PLC

The following drawing shows the connection to a PC by using a standard Sub-D-9 connector:

Connection of the RS232 interface:

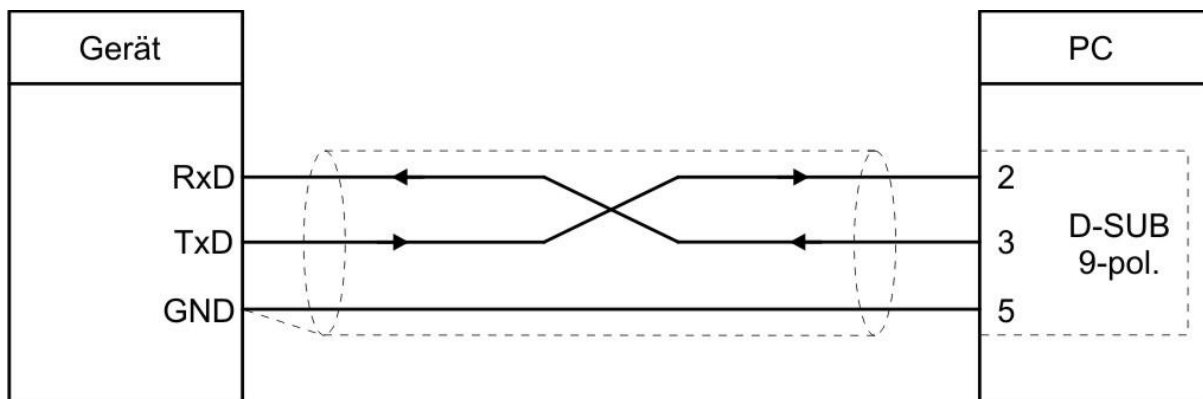

Connection of the RS485 interface:

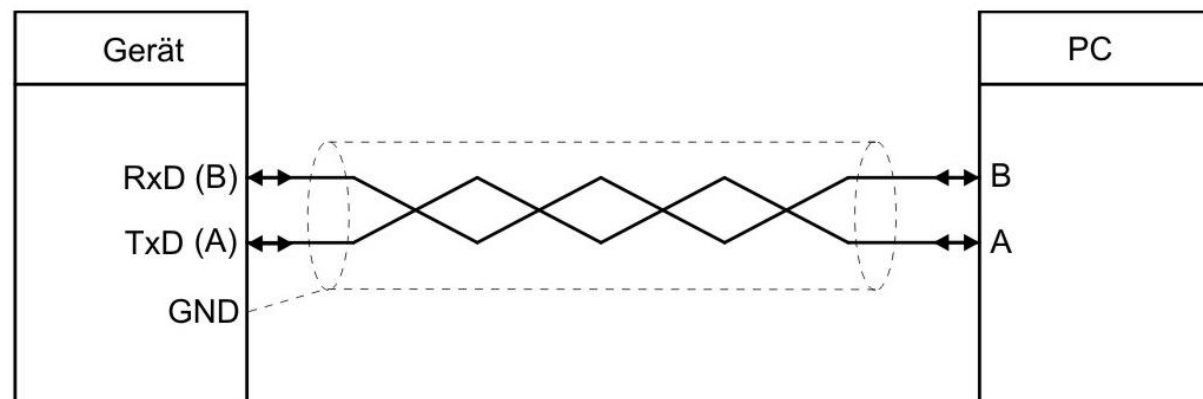

### 3.8. Control-Output (Option AO/AR/CO/CR)

Four control outputs are available at terminal 20, 21, 22 and 23.

Switching conditions can be set in the PRESELECTION MENU. The output Ctrl. Out1 – 4 are fast PNP outputs with a switching capability of 5 – 30 Volt / 200 mA per channel. The switching states is displayed (display with unit and status bar) as C1 ... C4.

The switching voltage of the outputs must be applied to input terminal 19 (COM+).

In case of switching inductive loads it is advisable to use external filtering of the coils. The switching states is displayed (display with unit and status bar) as C1 and C4.

Wiring of the control-outputs:

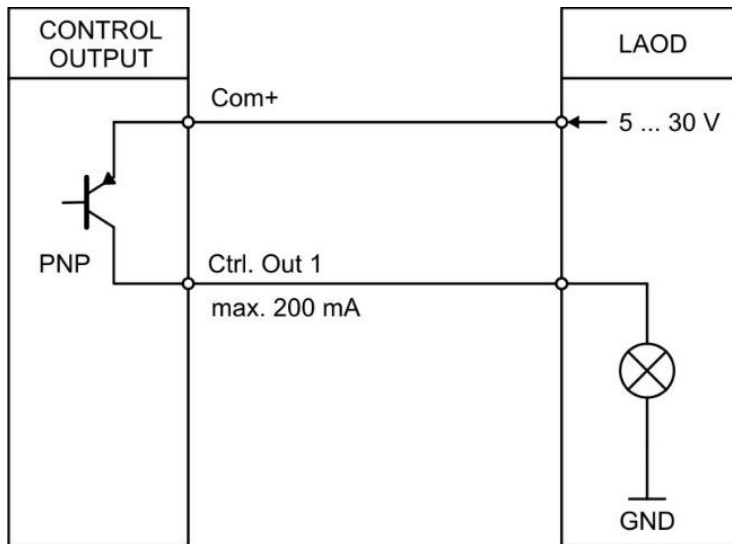

### 3.9. AC Power supply (Option AC)

The unit accepts AC supply from 115 to 230 V at the terminals 24 and 25. The power consumption depends on the level of the supply voltage with approx. 3VA and the additional current required at the auxiliary voltage output.

Devices with option AC can also be supplied with a DC voltage between 18 and 30 VDC at terminals 1 and 2.

### 3.10. Relay-Output (Option RL)

Two relay outputs with potential-free changeover contacts are available at terminal 27, 28, 29 and 30, 31, 32. Switching conditions can be set in the PRESELECTION MENU. The switching states are displayed (display with unit and status bar) as K1 and K2.

AC-switching capacity max 250 VAC/max. 3 A / max 750 VA

DC-switching capacity max 150 VDC /max. 2 A / max 50 W

Wiring of the relay outputs:

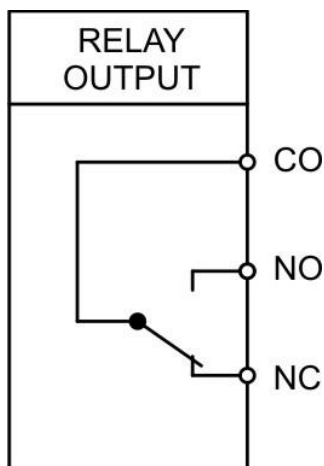

### 3.11. IO-Link (Option IO)

An interface for connecting to an IO-Link master is available at terminal 34, 35 and 36. The display device (IO-link device) must always be connected to a separate power supply (AC or DC).

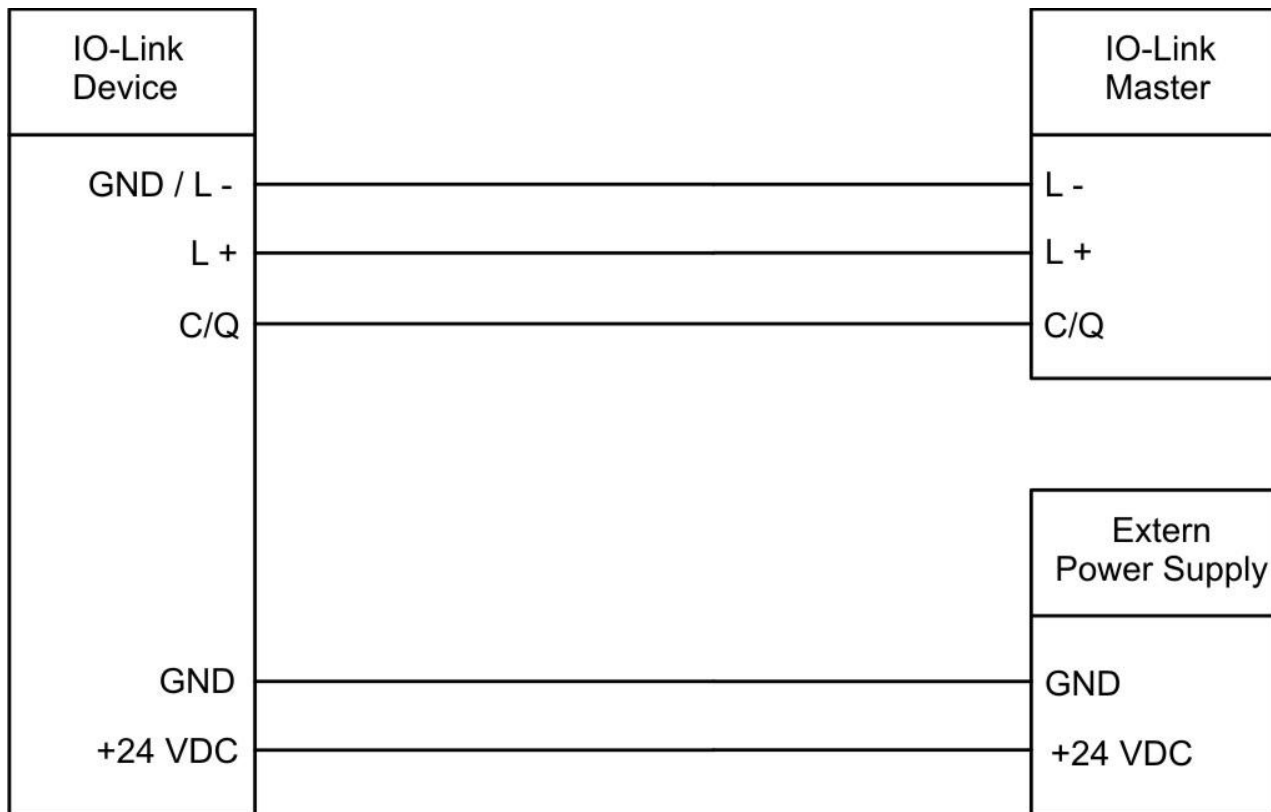

The display device (IO-link device) can be operated in two ways.

- **Display of 2 output process data (8 bytes):**

2 output process data are sent by the IO-Link master cyclically. The two values can be parameterized or scaled in the Menu IO-LINK PROPERTIES.

- **Display for analog sensors and data transmission of 6 input process data (32 Byte):**

6 input process data are sent to the IO-link master cyclically. The following values are submitted:

- Value 1: Result of input 1
- Value 2: Result of input 2
- Value 3: Result of the link from input 1 to input 2
- Value 4: Result of totalization of input 1
- Value 5: Result of totalization of input 2
- Value 6: Result of totalization of the link from input 1 to input 2

These functions/data are defined in the IO-link master.

For more information, see the graph in Chapter 2.2 of the function diagram and in the Chapter "IO-Link-Modul" in this manual.

## 4. Operation and touch screen

### 4.1. Screen structure for parametrization

The parameter menus and the parameters are described in chapter 5.

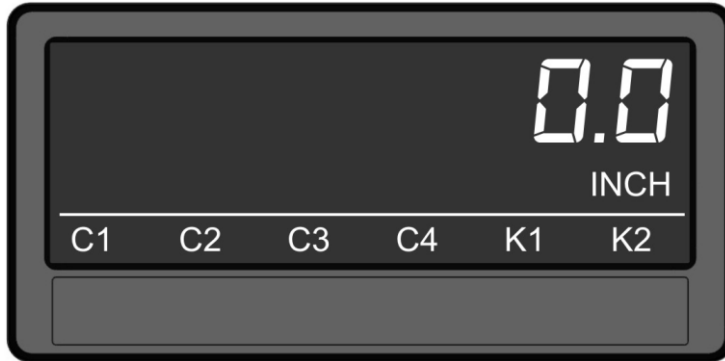

Start setup procedure:

To edit the parameters, press the touchscreen for 3 seconds.



Menu selection:

Select the parameter menu via arrow buttons and confirm with "OK".

The menu selection can be terminated with „C“.



Parameter selection:

Select the parameter via arrow buttons and confirm with „OK“.

The parameter selection can be terminated with „C“.



Parameter editing:

Edit the parameter via arrow button up and down, shift cursor via left and right and save with „OK“.

The parameter editing can be terminated with „C“.

Parameter changes becomes active only after closing the menu selection

## 4.2. Screen structure in operation

The following screens are available during operation. Depending on the device version and the selected operation mode, not all displays will be shown.

The source (IN1, IN2, ...) for the single channel display, the two channel display and the large display are defined in the DISPLAY MENU.



Single line display with unit and status bar

To switch to the next display, press the touch screen.

Control - or Relay status are only shown with Option AO, CO, RL.



Two-line display

To switch to the next display, press the top of the screen.



Two-line display with units

To switch to the next display, press the top of the screen.



Large Display (4 digits)

To switch to the next display, press the top of the screen.

This is only possible with activated parameter „LARGE DISPLAY“.



Continuation "Screen structure in operation":



Display for quick start for enter preselection values (PRESELECTION VALUES)

To switch to the next display, press the top of the screen or the "skip" button.

This is only possible with Option AO, CO, RL

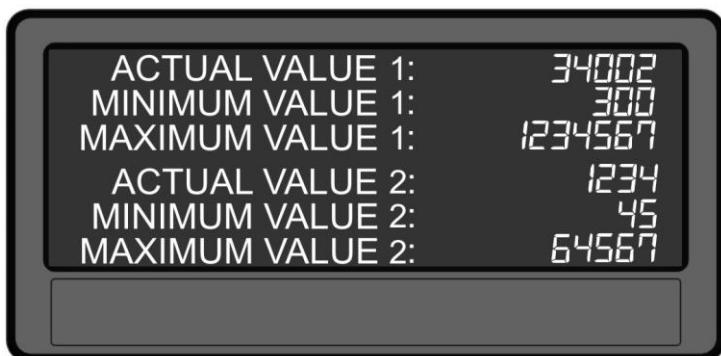

Display with actual / minimum / maximum values of input 1 and input 2

To switch to the next display, type on the touch screen.

### 4.3. Error messages

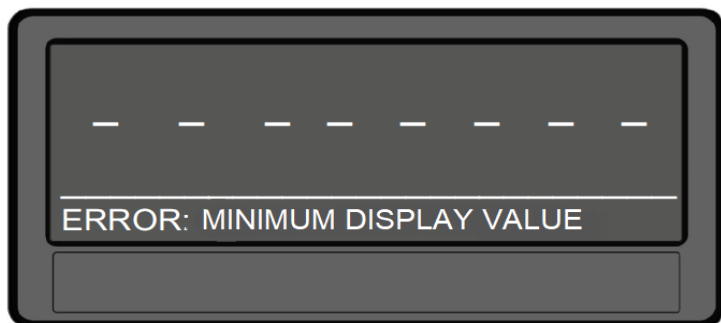

ERROR: MINIMUM DISPLAY VALUE

The display value of the single line display is less than -99 999 999

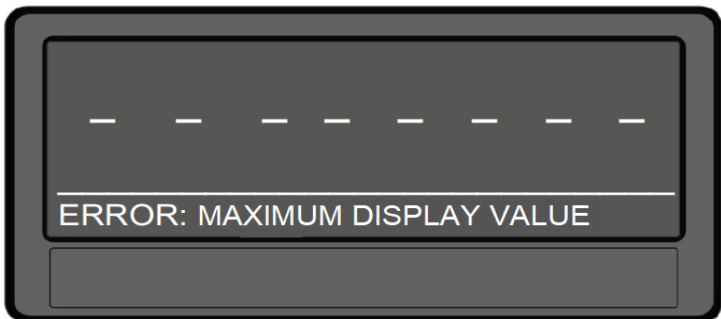

ERROR: MAXIMUM DISPLAY VALUE

The display value of the single line display is greater than +99 999 999

Continuation "Error messages":

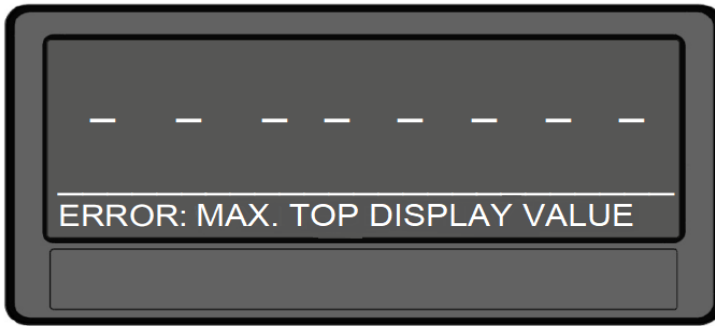

ERROR: MAX. TOP DISPLAY VALUE

Top display value of the two-line display is greater than +99 999 999

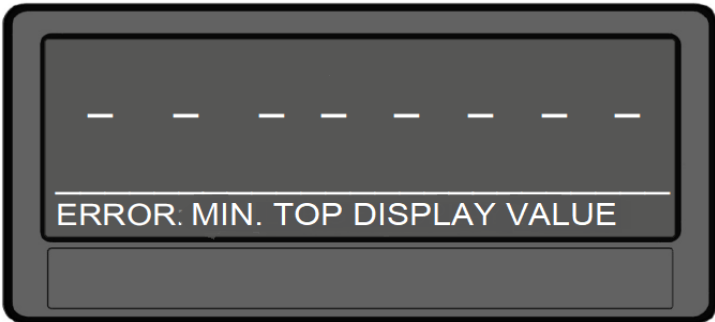

ERROR: MIN. TOP DISPLAY VALUE

Top display value of the two-line display is less than -99 999 999

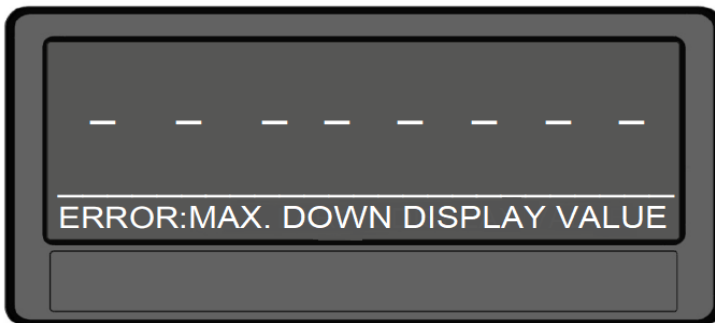

ERROR: MAX. DOWN DISPLAY VALUE

Down display value of the two-line display is greater than +99 999 999

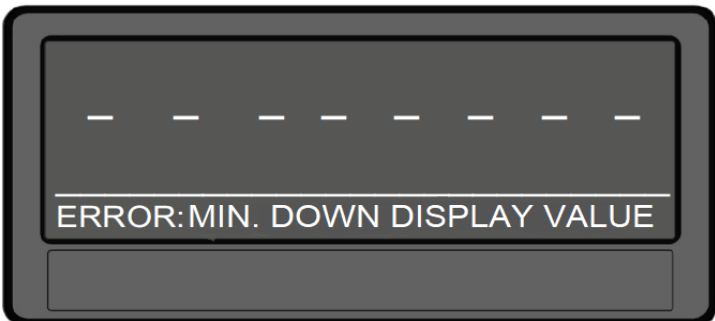

ERROR: MIN. DOWN DISPLAY VALUE

Down display value of the two-line display is less than -99 999 999



ERROR: MAX. LARGE DISPLAY VALUE

The display value of the large display is greater than + 9999

Continuation "Error messages":

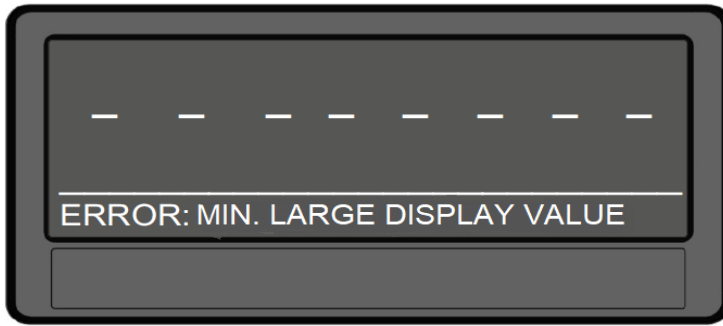

ERROR: MIN. LARGE DISPLAY VALUE

The display value of the large display is less than - 999



The error messages described are automatically reset as soon as the corresponding display value is within the representable range.

# 5. Parameter / Overview-Menu Structure

This section provides an overview of the menus and their parameters. The menu names are printed bold and the associated parameters are listed under the menu name. Depending on the device version and the selected operation mode, only the necessary menus / parameters are shown.

Menu / Parameter	Menu / Parameter
<b>GENERAL MENU</b>	<b>IN 2 PROPERTIES</b>
OPERATIONAL MODE	CONFIGURATION
PIN PRESELECTION	START VALUE
PIN PARAMETER	END VALUE
BACK UP MEMORY	DECIMAL POINT
FACTORY SETTINGS	SCALE UNITS
<b>IN 1 PROPERTIES</b>	SAMPLING TIME
CONFIGURATION	AVERAGE FILTER
START VALUE	OFFSET
END VALUE	LINEARIZATION
DECIMAL POINT	TOTALIZATION
SCALE UNITS	<b>IN 2 LINEARIZATION</b>
SAMPLING TIME	P1(X)
AVERAGE FILTER	P1(Y)
OFFSET	P2(X)
LINEARIZATION	P2(Y)
TOTALIZATION	...
<b>IN 1 LINEARIZATION</b>	...
P1(X)	P23(X)
P1(Y)	P23(Y)
P2(X)	P24(X)
P2(Y)	P24(Y)
...	<b>IN 2 TOTALIZATION</b>
...	TIME BASE
P23(X)	DIVIDER
P23(Y)	DECIMAL POINT
P24(X)	SCALE UNITS
P24(Y)	<b>LINKAGE PROPERTIES</b>
<b>IN 1 TOTALIZATION</b>	FACTOR
TIME BASE	DIVIDER
DIVIDER	ADDITIVE VALUE
DECIMAL POINT	DECIMAL POINT
SCALE UNITS	SCALE UNITS

Menu / Parameter
<b>IO LINK PROPERTIES</b>
IN1 FACTOR IN1 DIVIDER IN1 ADDITIVE VALUE IN1 DECIMAL POINT IN1 SCALE UNITS IN2 FACTOR IN2 DIVIDER IN2 ADDITIVE VALUE IN2 DECIMAL POINT IN2 SCALE UNITS
<b>PRESELECTION VALUES</b>
PRESELECTION 1 PRESELECTION 2 PRESELECTION 3 PRESELECTION 4
<b>PRESELECTION 1 MENU</b>
SOURCE 1 MODE 1 HYSTERESIS 1 PULSE TIME 1 OUTPUT TARGET 1 OUTPUT POLARITY 1 OUTPUT LOCK 1 START UP DELAY 1 EVENT COLOR 1
<b>PRESELECTION 2 MENU</b>
SOURCE 2 MODE 2 HYSTERESIS 2 PULSE TIME 2 OUTPUT TARGET 2 OUTPUT POLARITY 2 OUTPUT LOCK 2 START UP DELAY 2 EVENT COLOR 2
<b>PRESELECTION 3 MENU</b>
SOURCE 3 MODE 3 HYSTERESIS 3 PULSE TIME 3 OUTPUT TARGET 3 OUTPUT POLARITY 3 OUTPUT LOCK 3 START UP DELAY 3 EVENT COLOR 3

Menu / Parameter
<b>PRESELECTION 4 MENU</b>
SOURCE 4 MODE 4 HYSTERESIS 4 PULSE TIME 4 OUTPUT TARGET 4 OUTPUT POLARITY 4 OUTPUT LOCK 4 START UP DELAY 4 EVENT COLOR 4
<b>SERIAL MENU</b>
UNIT NUMBER SERIAL BAUD RATE SERIAL FORMAT SERIAL INIT SERIAL PROTOCOL SERIAL TIMER SERIAL VALUE MODBUS
<b>ANALOG OUT MENU</b>
ANALOG SOURCE ANALOG FORMAT ANALOG START ANALOG END ANALOG GAIN ANALOG OFFSET
<b>COMMAND MENU</b>
INPUT 1 ACTION INPUT 1 CONFIG INPUT 2 ACTION INPUT 2 CONFIG INPUT 3 ACTION INPUT 3 CONFIG
<b>DISPLAY MENU</b>
START DISPLAY SOURCE SINGLE SOURCE DUAL TOP SOURCE DUAL DOWN LARGE DISPLAY SOURCE LARGE COLOR BRIGHTNESS CONTRAST SCREEN SAVER UP-DATE-TIME FONT

## 5.1. General Menu

### OPERATIONAL MODE

This parameter specifies the selected measuring function..

0	<b>SINGLE</b>	Single channel mode, only input 1
1	<b>DUAL</b>	Dual channel mode, input 1 and input 2 separated
2	<b>IN1 + IN 2</b>	Dual channel mode, sum of input 1 and input 2
3	<b>IN1 – IN 2</b>	Dual channel mode, difference of input 1 and input 2
4	<b>IN1 x IN 2</b>	Dual channel mode, multiplication of input 1 and input 2
5	<b>IN1 / IN 2</b>	Dual channel mode, input 1 divide by input 2

### PIN PRESELECTION

This parameter defines the PIN-code to lock the quick start of the menu PRESELECTION VALUE for entering the preselection values\_(master PIN 6079).

This Lock function is only useful in conjunction with active lock function in PIN PARAMETER

	<b>0000</b>	No lock
	...	
	<b>9999</b>	Access after entering PIN-Code 9999

### PIN PARAMETER

This parameter defines the PIN-code for lock function of all parameters (master PIN 6079).

	<b>0000</b>	No lock
	...	
	<b>9999</b>	Parameterization of the unit after entering PIN-code 9999

### BACK UP MEMORY

0	<b>NO</b>	No back –up by power failure
1	<b>YES</b>	Backup by power failure, actual value will be saved, only by totalization

### FACTORY SETTINGS

0	<b>NO</b>	No default values are loaded
1	<b>YES</b>	Load default values of all parameters (grey marked default values)

## 5.2. IN 1 Properties

This menu defines the parameter for input 1.

<b>CONFIGURATION</b>		
This parameter defines the configuration of input 1.		
0	-10 ... 10 V	-10 ... 10 V
1	0 ... 20 MA	0 ... 20 mA
2	4 ... 20 MA	4 ... 20 mA

<b>START VALUE</b>		
This parameter defines the display value of an input signal of 0V, 0mA or 4mA. Signal values between START VALUE and END VALUE behave proportional.		
	-99999	Smallest start value
	0	Default value
	99999	Highest start value

<b>END VALUE</b>		
This parameter defines the display value of an input signal +10V or 20mA. Signal values between START VALUE and END VALUE behave proportional.		
	-99999	Smallest end value
	10000	Default value
	99999	Highest end value

<b>DECIMAL POINT</b>		
This value defines the position of the decimal point.		
0	NO	No decimal point
1	0000000.0	Decimal point at the specified position
2	000000.00	Decimal point at the specified position
3	00000.000	Default decimal point at the specified position
4	0000.0000	Decimal point at the specified position
5	000.00000	Decimal point at the specified position
6	00.000000	Decimal point at the specified position
7	0.0000000	Decimal point at the specified position

<b>SCALE UNITS</b>		
This parameter defines the required engineering unit. This parameter does not affect the calculation of the display value. The number of decimal places must be defined with the parameter DECIMAL POINT. A list of available units can be found in Chapter 6.2 Appendix: Display of scale units.		

Continuation "IN 1 Properties":

<b>SAMPLING TIME (S)</b>		
The configured value corresponds to the sampling interval. This time interval in seconds defines the time between the single samples of the analog signals. This parameter directly affects the response time of the unit.		
	<b>0,001</b>	Shortest sampling time
	<b>0,01</b>	Default value
	<b>60,000</b>	Longest sampling time

<b>AVERAGE FILTER</b>		
Selectable average filter function to avoid measuring fluctuations.		
	<b>0</b>	No average value will be created
	<b>1</b>	2 numbers of floating average cycles
	<b>2</b>	4 numbers of floating average cycles
	<b>3</b>	8 numbers of floating average cycles
	<b>4</b>	16 numbers of floating average cycles

<b>OFFSET</b>		
This parameter defines the zero offset / tara of the input. This parameter does not affect the TOTALIZATION function.		
	<b>-99.999</b>	Smallest offset
	<b>0</b>	Default value
	<b>+99.999</b>	Highest offset

<b>LINEARIZATION</b>			
This parameter defines the linearization function. The linearization points are defined in Menu IN 1 / IN 2 LINEARIZATION. See appendix.			
	<b>0</b>	<b>OFF</b>	No linearization
	<b>1</b>	<b>1 QUADRANT</b>	Linearization in the 1. quadrant
	<b>2</b>	<b>4 QUADRANT</b>	Linearization in all 4 quadrants

<b>TOTALIZATION</b>			
This parameter activates the totalization function. The settings will be done in Menu IN 1 / IN 2 TOTALIZATION. The totalization depends on the operation mode. See chart in chapter IN 1 Totalization.			
	<b>0</b>	<b>OFF</b>	No totalization
	<b>1</b>	<b>ON</b>	Totalization is active



### 5.3. IN 1 Linearization

The linearization points of input 1 are defined in this menu. This menu is shown only, if the linearization is selected in 1 PROPERTIES.

Linearization description and examples are shown in the appendix.

<b>P1(X) ... P24(X)</b>	
X-coordinate of the linearization point. This value representing the display value which the unit show in the display without linearization.	
<b>-99999999</b>	Smallest X-coordinate
<b>0</b>	Default value
<b>+99999999</b>	Largest X-coordinate

<b>P1(Y) ... P24(Y)</b>	
Y-coordinate of the linearization point This is the display value, which the unit should show in the display with linearization. E.g. P2(X) is replaced by P2(Y).	
<b>-99999999</b>	Smallest Y-coordinate
<b>0</b>	Default value
<b>+99999999</b>	Largest Y-coordinate

## 5.4. IN 1 Totalization

The totalization function is defined in this menu. This menu will only be showed, if the totalization is active in Menu IN 1 PROPERTIES.

The totalizator depends on the operation mode. See in the following list.

Operation mode	Totalisation		
	INPUT 1 TOTAL	INPUT 2 TOTAL	LINKAGE TOTAL
SINGLE	active	→ 0	→ 0
DUAL	active	active	→ 0
IN1 + IN 2	active	active	Total 1 + Total 2
IN1 – IN 2	active	active	Total 1 – Total 2
IN1 x IN 2	active	active	→ 0
IN1 / IN 2	active	active	→ 0

### TIME BASE

This parameter defines the time base of the totalization.  
It defines the time interval between the recordings of data.

0	<b>SECONDS</b>	The current value is added to INPUT 1 TOTAL every second
1	<b>MINUTES</b>	The current value is added to INPUT 1 TOTAL every minute
2	<b>HOURS</b>	The current value is added to INPUT 1 TOTAL every hour
3	<b>COMMAND</b>	The current value is added to INPUT 1 TOTAL, when using the command (ADD TO TOTAL 1) for the operation function at the control input (see Command Menu)

### DIVIDER

This parameter defines the divisor for the totalization.

0	1	No division
1	10	The result of the totalization is divided by 10
2	100	The result of the totalization is divided by 100
3	1000	The result of the totalization is divided by 1000

### DECIMAL POINT

This value defines the position of the decimal point.

0	<b>NO</b>	No decimal point
1	0000000.0	Decimal point at the specified position
2	000000.00	Decimal point at the specified position
3	00000.000	Decimal point at the specified position
4	0000.0000	Decimal point at the specified position
5	000.00000	Decimal point at the specified position
6	00.000000	Decimal point at the specified position
7	0.0000000	Decimal point at the specified position

### SCALE UNITS

This parameter defines the required engineering unit. This parameter does not affect the calculation of the display value. The number of decimal places must be defined with the parameter DECIMAL POINT. A list of available units can be found in Chapter 6.2 Appendix: Display of scale units.

## 5.5. IN 2 Properties

This menu defines the parameter for input 2.

### **CONFIGURATION**

Configuration of input 2, see IN 1 Properties

### **START VALUE**

Display value of input 2 at 0 V or 0/4 mA, see IN 1 Properties

### **END VALUE**

Display value of input 2 at +10 V or 20 mA, see IN 1 Properties

### **DECIMAL POINT**

Position of the decimal point, see IN 1 Properties

### **SCALE UNITS**

The displayed units, see IN 1 Properties

### **SAMPLING TIME (S)**

Sampling interval, see IN 1 Properties

### **AVERAGE FILTER**

Selectable averages filter function, see IN 1 Properties.

### **OFFSET**

Zero offset / tara, see IN 1 Properties

### **LINEARISATION**

Linearization function, see IN 1 Properties.

### **TOTALIZATION**

Totalization function, see IN 1 Properties.

## 5.6. IN 2 Linearization

The linearization points of input 2 are defined in this menu.

**P1(X) ... P24(X)**

X-coordinate of the linearization point, see IN 1 Linearization.

**P1(Y) ... P24(Y)**

Y-coordinate of the linearization point, see IN 1 Linearization.

## 5.7. IN 2 Totalization

The totalization function is defined in this menu.

**TIME BASE**

The time base of the totalization, see IN 1 Totalization

**DIVIDER**

The divisor for the totalization, see IN 1 Totalization.

**DECIMAL POINT**

Position of the decimal point, see IN 1 Totalization

**SCALE UNITS**

The displayed units, see IN 1 P Totalization

## 5.8. Linkage Properties

In this menu the parameters for the linked operation mode are defined. This menu is shown only, if in GENERAL MENU an operation mode (z.B. IN1 – IN2) with link was selected.

The parameters in Menu IN 1 PROPERTIES and IN 2 PROPERTIES have to be set, before using a linked operation mode.

The result of the link can be scaled with the following parameters.

<b>FACTOR</b>		
This parameter defines the factor, the result of the link will be charged.		
	<b>-99999999</b>	Smallest value
	<b>1</b>	Default value
	<b>99999999</b>	Highest end value

<b>DIVIDER</b>		
This parameter defines the divider, the result of the link will be charged..		
	<b>-99999999</b>	Smallest end value
	<b>1</b>	Default value
	<b>99999999</b>	Highest end value

<b>ADDITIVE VALUE</b>		
This parameter defines the additive constant, the result of the link will be charged.		
	<b>-99999999</b>	Smallest end value
	<b>0</b>	Default value
	<b>99999999</b>	Highest end value

<b>DECIMAL POINT</b>		
This value defines the position of the decimal point.		
	<b>0 NO</b>	No decimal point
	<b>1 0000000.0</b>	Decimal point at the specified position
	<b>2 000000.00</b>	Decimal point at the specified position
	<b>3 00000.000</b>	Decimal point at the specified position
	<b>4 0000.0000</b>	Decimal point at the specified position
	<b>5 000.00000</b>	Decimal point at the specified position
	<b>6 00.000000</b>	Decimal point at the specified position
	<b>7 0.0000000</b>	Decimal point at the specified position

<b>SCALE UNITS</b>		
This parameter defines the required engineering unit. This parameter does not affect the calculation of the display value. The number of decimal places must be defined with the parameter DECIMAL POINT. A list of available units can be found in Chapter 6.2 Appendix: Display of scale units.		

## 5.9. IO-Link Properties

This menu defines the parameters for the display of the two output process data.

This menu is only displayed if the device is equipped with the option IO (IO-Link Modul).

<b>IN1 FACTOR</b> (Multiplication factor)		
This parameter defines the factor the received value is multiplied with.		
	-99999999	Smallest value
	1	Default value
	99999999	Highest end value

<b>IN1 DIVIDER</b> (Dividing factor)		
This parameter defines the factor the received value is divided by.		
	-99999999	Smallest value
	1	Default value
	99999999	Highest end value

<b>IN1 ADDITIVE VALUE</b> (Additive value)		
This parameter defines the factor the received value is added with.		
	-99999999	Smallest value
	0	Default value
	99999999	Highest end value

<b>IN1 DECIMAL POINT</b> (decimal point)		
This setting determines the position of the decimal point.		
	0 NO	No decimal point
	1 0000000.0	Decimal point at the specified location
	2 000000.00	Decimal point at the specified location
	3 00000.000	Decimal point at the specified location
	4 0000.0000	Decimal point at the specified location
	5 000.00000	Decimal point at the specified location
	6 00.000000	Decimal point at the specified location
	7 0.0000000	Decimal point at the specified location

<b>IN1 SCALE UNITS</b>		
This parameter defines the required engineering unit. This parameter does not affect the calculation of the display value. The number of decimal places must be defined with the parameter DECIMAL POINT. A list of available units can be found in Chapter 6.2 Appendix: Display of scale units.		

<b>IN2 FACTOR</b> (multiplication factor for value 2, see IN 1 factor)
--

<b>IN2 DIVIDER</b> (dividing factor for value 2, see IN1 Divider)
---

<b>IN2 ADDITIVE VALUE</b> (additive value for value 2, see IN1 ADDITIVE VALUE)
--

<b>IN2 DECIMAL POINT</b> (decimal point for value 2, see IN1 DECIMAL POINT)
---

<b>IN2 SCALE UNITS</b> (scale units for value 2, see IN1 SCALING UNITS)
---

## 5.10. Preselection Values

This menu is used to set the preselection values or the switching points.

The preselection values / switching points are always referred to the display value.

This menu is only available for devices with option CO, AO or RL.

PRESELECTION 1 (Preselection / switching point 1)		
	-99999999	Smallest value
	1000	Default value
	+99999999	Highest value

PRESELECTION 2 (Preselection / switching point 2)		
	-99999999	Smallest value
	2000	Default value
	+99999999	Highest value

PRESELECTION 3 (Preselection / switching point 3)		
	-99999999	Smallest value
	3000	Default value
	+99999999	Highest value

PRESELECTION 4 (Preselection / switching point 4)		
	-99999999	Smallest value
	4000	Default value
	+99999999	Highest value

## 5.11. Preselection 1 Menu

Switching conditions for preselection 1. Output/ relay/ display switches under the following conditions.

This function is only available for devices with option CO, AO or RL.

SOURCE 1		
This parameter defines the reference source for PRESELECTION 1		
0	INPUT 1	the reference source is input 1
1	INPUT 2	the reference source is input 2
2	LINKAGE 1 – 2	the reference source is the result of the linking of input1 and input 2
3	INPUT 1 TOTAL	the reference source is input 1 with totalization
4	INPUT 2 TOTAL	the reference source is input 2 with totalization
5	LINKAGE TOTAL	the reference source is the result of the linking of input1 and input 2 with totalization
6	IO LINK VALUE 1	the reference source is the process data out value 1 sent by the IO-Link master
7	IO LINK VALUE 2	the reference source is the process data out value 2 sent by the IO-Link master
8	MINIMUM VALUE 1	minimum value, the reference source is input 1
9	MAXIMUM VALUE 1	maximum value, the reference source is input 1
10	MINIMUM VALUE 2	minimum value, the reference source is input 2
11	MAXIMUM VALUE 2	maximum value, the reference source is input 2

Continuation „Preselection 1 Menu“:

The totalization depends on the operation mode. See chart in chapter IN 1 Totalization.

<b>MODE 1</b>		
Switching conditions for preselection 1. Output/ relay/ display switches under the following conditions:		
0	$ \text{RESULT}  \geq  \text{PRES} $	Absolute value of the display value is greater or equal absolute value of PRESELECTION 1 With HYSTERESIS 1 not equal 0 the following switching condition is applied: Display value $\geq$ PRESELECTION 1 $\rightarrow$ ON, Display value $<$ PRESELECTION 1 – HYSTERESIS 1 $\rightarrow$ OFF
1	$ \text{RESULT}  \leq  \text{PRES} $	Absolute value of the display value is less or equal absolute value of PRESELECTION 1 (start-up suppression (START UP DELAY) is advisable) With HYSTERESIS 1 not equal 0 the following switching condition is applied: Display value $\leq$ PRESELECTION 1 $\rightarrow$ ON, Display value $>$ PRESELECTION 1 + HYSTERESIS 1 $\rightarrow$ OFF
2	$ \text{RESULT}  =  \text{PRES} $	Absolute value of the display value is equal absolute value of PRESELECTION 1 A range (Preselection +/- ½ Hysteresis) can be defined and monitored in conjunction with the hysteresis. With HYSTERESIS 1 not equal 0 the following switching condition is applied: Display value $>$ PRESELECTION 1 + ½ HYSTERESIS 1 $\rightarrow$ OFF, Display value $<$ PRESELECTION 1 - ½ HYSTERESIS 1 $\rightarrow$ OFF
3	$\text{RESULT} \geq \text{PRES}$	Display value is greater or equal PRESELECTION 1, e.g. overspeed With HYSTERESIS 1 not equal 0 the following switching condition is applied: Display value $\geq$ PRESELECTION 1 $\rightarrow$ ON, Display value $<$ PRESELECTION 1 – HYSTERESIS 1 $\rightarrow$ OFF
4	$\text{RESULT} \leq \text{PRES}$	Display value is less or equal PRESELECTION 1, e.g. underspeed (start-up suppression (START UP DELAY) is advisable) With HYSTERESIS 1 not equal 0 the following switching condition is applied: Display value $\leq$ PRESELECTION 1 $\rightarrow$ ON, Display value $>$ PRESELECTION 1 + HYSTERESIS 1 $\rightarrow$ OFF
5	$\text{RESULT} = \text{PRES}$	Display value is equal PRESELECTION 1. A range (Preselection +/- ½ Hysteresis) can be defined and monitored in conjunction with the hysteresis. With HYSTERESIS 1 not equal 0 the following switching condition is applied: Display value $>$ PRESELECTION 1 + ½ HYSTERESIS 1 $\rightarrow$ OFF, Display value $<$ PRESELECTION 1 - ½ HYSTERESIS 1 $\rightarrow$ OFF
6	$\text{RES} \geq \text{PRES-TRAIL}$	Trailing PRESELECTION 1: Display value is greater or equal PRESELECTION 2 – PRESELECTION 1, PRESELECTION 1 is the trailing preselection from PRESELECTION 2.

<b>HYSTERESIS 1</b>		
This parameter defines the switching hysteresis of the switch-off point for preselection 1		
	0	No switching hysteresis
	...	
	99999	Switching hysteresis of 99999



Continuation „Preselection 1 Menu“:

<b>PULSE TIME 1 (S)</b>		
Duration of output pulse for the switching condition of preselection 1		
	<b>0,000</b>	No output pulse (static signal)
	...	
	<b>60,000</b>	Pulse duration of 60 seconds

<b>OUTPUT TARGET 1</b>		
Assignment of an output or relay for the switching condition of preselection 1. If more than one switching condition is assigned to one output / relay, the output is set when at least one switching condition is true		
	<b>0 NO</b>	No assignment
	<b>1 CTRL OUT 1</b>	Switching condition assigned to "Ctrl. Out 1"
	<b>2 CTRL OUT 2</b>	Switching condition assigned to "Ctrl. Out 2"
	<b>3 CTRL OUT 3</b>	Switching condition assigned to "Ctrl. Out 3"
	<b>4 CTRL OUT 4</b>	Switching condition assigned to "Ctrl. Out 4"
	<b>5 RELAY 1</b>	Switching condition assigned to "Rel. 1"
	<b>6 RELAY 2</b>	Switching condition assigned to "Rel. 2"

<b>OUTPUT POLARITY 1</b>		
Polarity for the switching condition of preselection 1		
	<b>0 ACTIVE HIGH</b>	Switching condition is true → Active „HIGH“
	<b>1 ACTIVE LOW</b>	Switching condition is true → Active „LOW“

<b>OUTPUT LOCK 1</b>		
Latch for the switching condition of preselection 1		
	<b>0 NO</b>	No latch for preselection
	<b>1 YES</b>	Latch for preselection (command LOCK RELEASE will clear latch)

<b>START UP DELAY 1 (S)</b>		
Start-up suppression for the switching condition of preselection 1. This adjustment is only valid for the switching condition  RESULT <= PRES  or RESULT<=PRES START UP DELAY is set to this parameter, when the display value is <=0. The timer starts with a display value > 0. The monitoring function remains deactivated until the set time has elapsed. (Start Up Delay 3 and 4 have an automatic start up suppression).		
	<b>0.000</b>	No start-up suppression
	...	
	<b>60.000</b>	Start-up suppression in seconds

<b>EVENT COLOR 1</b>		
Event-depending change of the display color for the switching condition of preselection 1. EVENT COLOR 1 has the lowest priority. EVENT COLOR 2 ... 4 are allowed to overwrite this color change.		
	<b>0 NO CHANGE</b>	No color change.
	<b>1 CHANGE TO RED</b>	Color change to red
	<b>2 CHANGE TO GREEN</b>	Color change to green
	<b>3 CHANGE TO YELLOW</b>	Color change to yellow

## 5.12. Preselection 2 Menu

### SOURCE 2

The reference source for PRESELECTION 2, see PRESELECTION 1 MENU

### MODE 2

Switching conditions for preselection 2, see PRESELECTION 1 MENU (expect trailing preselection)

		See chapter PRESELECTION 1 MENU
6	RES>=PRES-TRAIL	Trailing preselection 2: Display value is greater or equal to PRESELECTION 1 – PRESELECTION 2 PRESELECTION 2 is the trailing preselection from PRESELECTION 1.

### HYSTERESIS 2

This parameter defines the switching hysteresis of the switch-off point for preselection 2.

See chapter PRESELECTION 1 MENU

### PULSE TIME 2 (S)

Duration of output pulse for the switching condition of preselection 2.

See chapter PRESELECTION 1 MENU.

### OUTPUT TARGET 2

Assignment of an output or relay for the switching condition of preselection 2.

See chapter PRESELECTION 1 MENU (expect default value).

		see PRESELECTION 1 MENU
2	CTRL OUT 2	Assignment of switching conditions at Ctrl. Out 2

### OUTPUT POLARITY 2

Polarity for the switching condition of preselection 2.

See chapter PRESELECTION 1 MENU.

### OUTPUT LOCK 2

Latch for the switching condition of preselection 2.

See chapter PRESELECTION 1 MENU.

### START UP DELAY 2 (S)

Start-up suppression for the switching condition of preselection 2.

See chapter PRESELECTION 1 MENU.

(Start Up Delay 3 and 4 have an automatic start up suppression).

### EVENT COLOR 2

Event-depending change of the display color for the switching condition of preselection 2.

See chapter PRESELECTION 1 MENU.

## 5.13. Preselection 3 Menu

### SOURCE 3

The reference source for PRESELECTION 3, see PRESELECTION 1 MENU

### MODE 3

Switching conditions for preselection 3, see PRESELECTION 1 MENU (expect trailing preselection)

			See chapter PRESELECTION 1 MENU
6	RES>=PRES-TRAIL		Trailing preselection 3: Display value is greater or equal to PRESELECTION 4 – PRESELECTION 3 PRESELECTION 3 is the trailing preselection from PRESELECTION 4.

### HYSTERESIS 3

This parameter defines the switching hysteresis of the switch-off point for preselection 3.  
See chapter PRESELECTION 1 MENU.

### PULSE TIME 3 (S)

Duration of output pulse for the switching condition of preselection 3.  
See chapter PRESELECTION 1 MENU (except default value).

### OUTPUT TARGET 3

Assignment of an output or relay for the switching condition of preselection 3.  
See chapter PRESELECTION 1 MENU.

			see PRESELECTION 1 MENU
3	CTRL OUT 3		Assignment of switching conditions at Ctrl. Out 3

### OUTPUT POLARITY 3

Polarity for the switching condition of preselection 3.  
See chapter PRESELECTION 1 MENU.

### OUTPUT LOCK 3

Latch for the switching condition of preselection 3.  
See chapter PRESELECTION 1 MENU.

### START UP DELAY 3

Start-up suppression for the switching condition of preselection 3.

This adjustment is only valid for the switching condition  $|\text{RESULT}| \leq |\text{PRES}|$  or  $\text{RESULT} \leq$

Automatic start up suppression is activated, when the parameter is switched on and the display value is  $\leq 0$ . The monitoring function remains deactivated until the preset value / switching point is exceeded for the first time. (Start Up Delay 1 and 2 have a time-dependent start up suppression).

0	OFF	No start-up suppression
1	AUTO	Automatic start up suppression, until the preselection value / switching point is exceeded for the first time.

### EVENT COLOR 3

Event-dependending change of the display color for the switching condition of preselection 3.  
See chapter PRESELECTION 1 MENU.

## 5.14. Preselection 4 Menu

### SOURCE 4

The reference source for PRESELECTION 4, see PRESELECTION 1 MENU

### MODE 4

Switching conditions for preselection 4, see PRESELECTION 1 MENU (expect trailing preselection)

		See chapter PRESELECTION 1 MENU
6	RES>=PRES-TRAIL	Trailing preselection 4: Display value is greater or equal to PRESELECTION 3 – PRESELECTION 4 PRESELECTION 4 is the trailing preselection from PRESELECTION 3.

### HYSTERESIS 4

This parameter defines the switching hysteresis of the switch-off point for preselection 4.  
See chapter PRESELECTION 1 MENU.

### PULSE TIME 4 (S)

Duration of output pulse for the switching condition of preselection 3.  
See chapter PRESELECTION 1 MENU.

### OUTPUT TARGET 4

Assignment of an output or relay for the switching condition of preselection 4.  
See chapter PRESELECTION 1 MENU (except default value)..

		see PRESELECTION 1 MENU
4	CTRL OUT 4	Assignment of switching conditions at Ctrl. Out 4

### OUTPUT POLARITY 4

Polarity for the switching condition of preselection 4.  
See chapter PRESELECTION 1 MENU.

### OUTPUT LOCK 4

Latch for the switching condition of preselection 4.  
See chapter PRESELECTION 1 MENU.

### START UP DELAY 4

Start-up suppression for the switching condition of preselection 4, see PRESELECTION 3 MENU.  
Automatic start up suppression is activated, when the parameter is switched on and the display value is  $\leq 0$ . The monitoring function remains deactivated until the preset value / switching point is exceeded for the first time. (Start Up Delay 1 and 2 have a time-dependent start up suppression).

0	OFF	Automatic start up suppression,
1	AUTO	until the preselection value / switching point is exceeded for the first time.

### EVENT COLOR 4

Event-dependending change of the display color for the switching condition of preselection 4.  
See chapter PRESELECTION 1 MENU.

## 5.15. Serial Menu

This menu defines the basic settings of serial interface.

This function is only available for devices with option CO or A0

UNIT NUMMER		
This parameter defines serial device addresses. The addresses between 11 and 99 can be assigned to the devices. Addresses with zero are not allowed, there are used as broadcast addresses.		
	11	Smallest address
	...	
	99	Highest address

SERIAL BAUD RATE		
This parameter defines the serial baud rate		
0	9600	9600 baud
1	19200	19200 baud
2	38400	38400 baud

SERIAL FORMAT				
This parameter defines the bit data format.				
0	7-EVEN-1	7 data	Parity even	1 Stop
1	7-EVEN-2	7 data	Parity even	2 Stops
2	7-ODD-1	7 data	Parity odd	1 Stop
3	7-ODD-2	7 data	Parity odd	2 Stops
4	7-NONE-1	7 data	no Parity	1 Stop
5	7-NONE-2	7 data	no Parity	2 Stops
6	8-EVEN-1	8 data	Parity even	1 Stop
7	8-ODD-1	8 data	Parity odd	1 Stop
8	8-NONE-1	8 data	no Parity	1 Stop
9	8-NONE-2	8 data	no Parity	2 Stops

SERIAL INIT		
This parameter defines the baud rate for the initialization to the user interface OS6.0. With settings larger than 9600 the initialization time can be reduced.		
0	NO	Initialization with 9600 baud. Then the device operates with the value selected by the user.
1	YES	Initialization with the baud rate set by SERIAL BAUD RATE. Then the device operates with the value selected by the user.

Continuation „Serial Menu“:

<b>SERIAL PROTOCOL</b>													
<p>Determines the sequence of characters send, when using the serial output for cyclic data transmission under time control (xxxxxxx = value SERIAL VALUE).                      Setting „1“ removes the unit address from the string which allows a slight faster transmission cycle.</p>													
<b>0</b>	<p>Transmission report = Unit Nr., +/-, data, LF, CR</p> <table border="1" style="margin-left: 40px;"> <tr> <td>1</td><td>1</td><td>+/-</td><td>X</td><td>X</td><td>X</td><td>X</td><td>X</td><td>X</td><td>X</td><td>LF</td><td>CR</td> </tr> </table>	1	1	+/-	X	X	X	X	X	X	X	LF	CR
1	1	+/-	X	X	X	X	X	X	X	LF	CR		
<b>1</b>	<p>Transmission report = +/-, data, LF, CR</p> <table border="1" style="margin-left: 40px;"> <tr> <td>+/-</td><td>X</td><td>X</td><td>X</td><td>X</td><td>X</td><td>X</td><td>X</td><td>X</td><td>LF</td><td>CR</td> </tr> </table>	+/-	X	X	X	X	X	X	X	X	LF	CR	
+/-	X	X	X	X	X	X	X	X	LF	CR			

<b>SERIAL TIMER (S)</b>	
<p>This register determines the cycle time in seconds for cycling transmission of SERIAL VALUE when using the serial output. (On a serial request, the cycling transmission is stopped for 20 s)</p>	
<b>0.000</b>	All cyclic transmission is switched off. The unit will send data upon a serial request or with command SERIAL PRINT.
...	
<b>60.000</b>	Cycle time in seconds.

<b>SERIAL VALUE</b>			
This parameter defines the value to be transmitted.			
Setting	Code	Register contents	
<b>0</b>	:0	Value input 1	
<b>1</b>	:1	Value input 2	
<b>2</b>	:2	Result of the linking of input1 and input 2	
<b>3</b>	:3	Result totalizator 1	
<b>4</b>	:4	Result totalizator 2	
<b>5</b>	:5	Result of the linking of 1 and 2 with totalization	
<b>6</b>	:6	Minimum value input 1	
<b>7</b>	:7	Maximum value input 1	
<b>8</b>	:8	Minimum value input 2	
<b>9</b>	:9	Maximum value input 2	

<b>MODBUS</b>	
<p>This parameter enables the Modbus protocol and determines the Modbus address.                      For details of the Modbus communication please refer to the additional manual Modbus_RTU</p>	
<b>0</b>	<p>Modbus disabled                      Serial interface is using Lecom protocol (Motrona default protocol)</p>
<b>1 ... 247</b>	<p>Modbus enabled: Serial interface is using Modbus RTU protocol                      The set value is the Modbus address of the device.</p>

## 5.16. Analog Out Menu

This menu defines the basic settings of the analog output. This function is only available for devices with option A0.

<b>ANALOG SOURCE</b>		
This parameter defines the reference source for the Analog Output		
0	<b>INPUT 1</b>	the reference source is input 1
1	<b>INPUT 2</b>	the reference source is input 2
2	<b>LINKAGE 1 – 2</b>	the reference source is the result of the linking of input1 and input 2
3	<b>INPUT 1 TOTAL</b>	the reference source is input 1 with totalization
4	<b>INPUT 2 TOTAL</b>	the reference source is input 2 with totalization
5	<b>LINKAGE TOTAL</b>	the reference source is the result of the linking of input1 and input 2 with totalization
6	<b>IO LINK VALUE 1</b>	the reference source is the process data out value 1 sent by the IO-Link master
7	<b>IO LINK VALUE 2</b>	the reference source is the process data out value 2 sent by the IO-Link master
8	<b>MINIMUM VALUE 1</b>	minimum value, the reference source is input 1
9	<b>MAXIMUM VALUE 1</b>	maximum value, the reference source is input 1
10	<b>MINIMUM VALUE 2</b>	minimum value, the reference source is input 2
11	<b>MAXIMUM VALUE 2</b>	maximum value, the reference source is input 2

The totalization depends on the operation mode. See chart in chapter IN 1 Totalization.

<b>ANALOG FORMAT</b>		
This parameter defines the output characteristics. The analogue output is proportional to the display value. With setting ANALOG FORMAT (-10 ... +10 V) in MODE COUNTER the polarity of the analog output depends on the polarity of the display value.		
0	<b>-10...10V</b>	-10 ... +10 V
1	<b>0...20MA</b>	0 ... 20 mA
2	<b>4...20MA</b>	4 ... 20 mA

<b>ANALOG START</b>		
This parameter defines the start value of the analog conversion. This start value is corresponding to the display value for an analog output of 0 V or 0/4 mA.		
	<b>-99999999</b>	Smallest start value
	<b>0</b>	Default value
	<b>+99999999</b>	Highest start value

<b>ANALOG END</b>		
This parameter defines the end value of the analog conversion. This end value is corresponding to the display value for an analog output of (+/-) 10 V or 20mA.		
	<b>-99999999</b>	Smallest end value
	<b>10000</b>	Default Wert
	<b>+99999999</b>	Highest end value

Continuation „Analog Out Menu“:

**ANALOG GAIN (%)**

This parameter specifies the maximum conversion of the analog output in %.

e. g. 102.00 corresponds to a conversion of 10.2 V or 20.4 mA, when the ANALOG END value is reached.

e. g. 95.00 corresponds to a conversion of 9.5 V or 18 mA, when the ANALOG END value is reached..

	<b>0,00</b>	Smallest gain
	<b>100,00</b>	Default value
	<b>110,00</b>	Highest gain

**ANALOG OFFSET (%)**

This parameter defines the zero offset of the analog output.

z. B. 0.20 result in an offset of 0.02 V or 0.04 mA at ANALOG START value

	<b>-99,99</b>	Smallest offset
	<b>0</b>	Default value
	<b>+99,99</b>	Highest offset



## 5.17. Command Menu

INPUT 1 ACTION			
This parameter defines the function of the input "Ctrl. In 1".			
0	NO	No function	
1	TARA INPUT 1	Value of input 1 is stored as an OFFSET of input 1	(d)
2	TARA INPUT 2	Value of input 2 is stored as an OFFSET of input 2	(d)
3	TARA INPUT 1+2	Value of input 1 is stored as an OFFSET of input 1 Value of input 2 is stored as an OFFSET of input 2	(d)
4	RESET TOTAL 1	Value of totalizator 1 is reset to zero	(d) (s)
5	RESET TOTAL 2	Value of totalizator 2 is reset to zero	(d) (s)
6	RESET TOTAL 1+2	Value of totalizator 1 is reset to zero Value of totalizator 2 is reset to zero	(d) (s)
7	TEACH PRESEL. 1	Value (SOURCE 1) is stored as PRESELECTION 1	(d)
8	TEACH PRESEL. 2	Value (SOURCE 2) is stored as PRESELECTION 2	(d)
9	TEACH PRESEL. 3	Value (SOURCE 3) is stored as PRESELECTION 3	(d)
10	TEACH PRESEL. 4	Value (SOURCE 4) is stored as PRESELECTION 4	(d)
11	SCROLL DISPLAY	Display switching (see chapter Screen structure in operation)	(d)
12	RESET MIN/MAX	Reset the Min. / Max. values	(d) (s)
13	CLEAR LOOP TIME	N.A.	
14	ACTIVATE	N.A.	
15	STORE DATA	N.A.	
16	TESTPROGRAM	N.A.	
17	SET RED COLOR	Red display: Event-depending change of the display color by a switching condition is possible (see PRESELECTION 1...4 MENU)	(d)
18	SET GREEN COLOR	Green display: Event-depending change of the display color by a switching condition is possible (see PRESELECTION 1...4 MENU)	(d)
19	SET YELLOW COLOR	Yellow display: Event-depending change of the display color by a switching condition is possible (see PRESELECTION 1...4 MENU)	(d)
20	FREEZE	Freezing the display value	(s)
21	KEY LOCK	Key looked touch screen	(s)
22	LOCK RELEASE	No latch for preselection	(d)
23	SERIAL PRINT	Send serial data, see SERIAL VALUE	(d)
24	START PRESELECT	N.A.	
25	ADD TO TOTAL 1	Adds the current value of input 1 to INPUT 1 TOTAL	(d)
26	ADD TO TOTAL 2	Adds the current value of input 2 to INPUT 2 TOTAL	(d)
27	INC. BRIGHTNESS	Display brightness is increased	(d) (s)
28	DEC. BRIGHTNESS	Display brightness is reduced	(d) (s)

(s) = statistical characteristic (level evaluation)  
INPUT CONFIG must be set to ACTIVE LOW/HIGH

(d) = dynamical characteristic (edge evaluation)  
INPUT CONFIG must be set to RISING/FALLING EDGE

Continuation „Command Menu“:

<b>INPUT 1 CONFIG</b>		
This parameter defines the switching characteristics of the input "Ctrl. In 1".		
0	ACTIVE LOW	Active at „LOW“ (static)
1	ACTIVE HIGH	Active at „HIGH“ (static)
2	RISING EDGE	Activate at rising edge (dynamic)
3	FALLING EDGE	Activate at falling edge (dynamic)

<b>INPUT 2 ACTION</b>
This parameter defines the function of the input "Ctrl. In 2". See parameter INPUT 1 ACTION

<b>INPUT 2 CONFIG</b>
This parameter defines the switching characteristics of the input "Ctrl. In 2". See parameter INPUT 1 CONFIG.

<b>INPUT 3 ACTION</b>
This parameter defines the function of the input "Ctrl. In 3". See parameter INPUT 1 ACTION.

<b>INPUT 3 CONFIG</b>
This parameter defines the switching characteristics of the input "Ctrl. In 3". See parameter INPUT 1 CONFIG.

## 5.18. Display Menu

Parameter changes become active only after closing the menu selection.

<b>START DISPLAY</b>		
This parameter defines the start display after switching on the device.		
0	SINGLE	Single-line display The source must be defined in SOURCE SINGLE
1	DUAL	Two-line display The sources must be defined in SOURCE DUAL TOP / DOWN.
2	DUAL WITH UNIT	Two-line display with units The sources must be defined in SOURCE DUAL TOP / DOWN.
3	LARGE	Large display (only with active parameter "LARGE DISPLAY") The source must be defined in SOURCE LARGE
4	QUICKSTART	Display with quick start function. (Only with option AO, CO, RL)
5	MINIMUM/MAXIMUM	Display with actual / minimum / maximum values of input 1 and input 2

SOURCE SINGLE (Reference source for single-line display)		
0	INPUT 1	the reference source is input 1
1	INPUT 2	the reference source is input 2
2	LINKAGE 1 – 2	the reference source is the result of the linking of input1 and input 2
3	INPUT 1 TOTAL	the reference source is input 1 with totalization
4	INPUT 2 TOTAL	the reference source is input 2 with totalization
5	LINKAGE TOTAL	the reference source is the result of the linking of input1 and input 2 with totalization
6	IO LINK VALUE 1	the reference source is the process data out value 1 sent by the IO-Link master
7	IO LINK VALUE 2	the reference source is the process data out value 2 sent by the IO-Link master
8	MINIMUM VALUE 1	minimum value, the reference source is input 1
9	MAXIMUM VALUE 1	maximum value, the reference source is input 1
10	MINIMUM VALUE 2	minimum value, the reference source is input 2
11	MAXIMUM VALUE 2	maximum value, the reference source is input 2

SOURCE DUAL TOP (Reference source for two-line display, first line)		
0	INPUT 1	the reference source is input 1
1	INPUT 2	the reference source is input 2
2	LINKAGE 1 – 2	the reference source is the result of the linking of input1 and input 2
3	INPUT 1 TOTAL	the reference source is input 1 with totalization
4	INPUT 2 TOTAL	the reference source is input 2 with totalization
5	LINKAGE TOTAL	the reference source is the result of the linking of input1 and input 2 with totalization
6	IO LINK VALUE 1	the reference source is the process data out value 1 sent by the IO-Link master
7	IO LINK VALUE 2	the reference source is the process data out value 2 sent by the IO-Link master
8	MINIMUM VALUE 1	minimum value, the reference source is input 1
9	MAXIMUM VALUE 1	maximum value, the reference source is input 1
10	MINIMUM VALUE 2	minimum value, the reference source is input 2
11	MAXIMUM VALUE 2	maximum value, the reference source is input 2

SOURCE DUAL DOWN (Reference source for two-line display, second line)		
0	INPUT 1	the reference source is input 1
1	INPUT 2	the reference source is input 2
2	LINKAGE 1 – 2	the reference source is the result of the linking of input1 and input 2
3	INPUT 1 TOTAL	the reference source is input 1 with totalization
4	INPUT 2 TOTAL	the reference source is input 2 with totalization
5	LINKAGE TOTAL	the reference source is the result of the linking of input1 and input 2 with totalization
6	IO LINK VALUE 1	the reference source is the process data out value 1 sent by the IO-Link master
7	IO LINK VALUE 2	the reference source is the process data out value 2 sent by the IO-Link master
8	MINIMUM VALUE 1	minimum value, the reference source is input 1
9	MAXIMUM VALUE 1	maximum value, the reference source is input 1
10	MINIMUM VALUE 2	minimum value, the reference source is input 2
11	MAXIMUM VALUE 2	maximum value, the reference source is input 2

LARGE DISPLAY		
This parameter is used to turn on or off the large display window. Using the divider ratio, the large display value can also be divided.		
0	NO	Large display is switched off
1	1:1	Large display with divider ratio 1:1
2	1:10	Large display with divider ratio 1:10
3	1:100	Large display with divider ratio 1:100
4	1:1000	Large display with divider ratio 1:1000
5	1:10000	Large display with divider ratio 1:10000

SOURCE LARGE (Reference source for large display)		
Parameter only visible with activated parameter "LARGE DISPLAY".		
0	INPUT 1	the reference source is input 1
1	INPUT 2	the reference source is input 2
2	LINKAGE 1 – 2	the reference source is the result of the linking of input1 and input 2
3	INPUT 1 TOTAL	the reference source is input 1 with totalization
4	INPUT 2 TOTAL	the reference source is input 2 with totalization
5	LINKAGE TOTAL	the reference source is the result of the linking of input1 and input 2 with totalization
6	IO LINK VALUE 1	the reference source is the process data out value 1 sent by the IO-Link master
7	IO LINK VALUE 2	the reference source is the process data out value 2 sent by the IO-Link master
8	MINIMUM VALUE 1	minimum value, the reference source is input 1
9	MAXIMUM VALUE 1	maximum value, the reference source is input 1
10	MINIMUM VALUE 2	minimum value, the reference source is input 2
11	MAXIMUM VALUE 2	maximum value, the reference source is input 2

The totalization depends on the operation mode. See chart in chapter IN 1 Totalization.

Continuation „Display Menu:“

<b>COLOR</b>			
This parameter defines the display color. Event-depending change of the display color by a switching condition is possible (see PRESELECTION 1...4 MENU) Event-depending changes are only available for devices with option C0350, A0350 or RL350.			
	<b>0</b>	<b>RED</b>	Red display
	<b>1</b>	<b>GREEN</b>	Green display
	<b>2</b>	<b>YELLOW</b>	Yellow display

<b>BRIGHTNESS (%)</b>			
This parameter defines the brightness of the display in percent			
	<b>10</b>		Min. brightness
	<b>80</b>		Default value
	<b>100</b>		Max. brightness

<b>CONTRAST</b>			
This parameter defines the viewing angle.			
	<b>0</b>		Viewing angle from top
	<b>1</b>		Viewing angle from center
	<b>2</b>		Viewing angle from bottom

<b>SCREEN SAVER (S)</b>			
This parameter defines the time in seconds until the display is switched off, after the last touch action. A new touch action will activate the display again.			
	<b>0</b>		No switch off
	<b>...</b>		
	<b>9999</b>		Longest time to switch off

<b>UP-DATE-TIME (S)</b>			
This parameter defines the update time in seconds of the display only.			
	<b>0,005</b>		Shortest update time
	<b>0,1</b>		Default value
	<b>9,999</b>		Longest update time

<b>FONT</b>			
This parameter defines the setting of the font style.			
	<b>0</b>		Standard
	<b>1</b>		Font 1

# 6. Appendix

## 6.1. Data readout via serial interface

All codes shown in the parameter SERIAL VALUE are available for serial readout by PC or PLC. The communication of Motrona devices is based on the Drivecom protocol according to ISO 1745 or the Modbus RTU protocol. All protocol details can be found in our manual SERPRO (Drivecom) which is available for download from our homepage [www.motrona.com](http://www.motrona.com) and in the chapter "Modbus RTU Interface" in this manual.

**To request for a data transmission you must send the following request string to the converter:**

EOT	AD1	AD2	C1	C2	ENQ
-----	-----	-----	----	----	-----

EOT = control character (Hex 04)

AD1 = unit address, High Byte

AD2 = unit address, Low Byte

C1 = register code, High Byte

C2 = register code, Low Byte

ENQ = control character (Hex 05)

The following example shows the request string for readout of the actual input frequency of a monitor (Code:1) from a unit with unit address 11:

ASCII-Code:	EOT	1	1	:	1	ENQ
Hex-Code:	04	31	31	3A	31	05
Binary-Code:	0000 0100	0011 0001	0011 0001	0011 1010	0011 0001	0000 0101

**After a correct request, the unit will respond:**

STX	C1	C2	xxxxx	ETX	BCC
-----	----	----	-------	-----	-----

STX = control character (Hex 02)

C1 = register code, High Byte

C2 = register code, Low Byte

xxxxx = readout data

ETX = control character (Hex 03)

BCC = block check character

## 6.2. Modbus RTU Interface

The Modbus interface of the touchMatrix® series is a standard Modbus RTU Slave and provides the following Modbus functions:

- Read Coils
- Write Single Coil
- Read Holding Registers
- Write Multiple Registers
- Diagnosis

For the operation of the interface module and the understanding of this manual basic knowledge in Modbus RTU communication is presupposed.

### 6.2.1. Parameter setting

Required parameter settings in DX350 / DX355 "Serial menu":

#### UNIT NUMMER

Not valid for Modbus communication  
(For setting of Modbus address see parameter "MODBUS")

#### SERIAL BAUD RATE

This parameter defines the serial baud rate

0	9600	9600 baud
1	19200	19200 baud
2	38400	38400 baud

#### SERIAL FORMAT

This parameter defines the bit data format.

0	7-EVEN-1	Do not use with Modbus protocol
1	7-EVEN-2	
2	7-ODD-1	
3	7-ODD-2	
4	7-NONE-1	
5	7-NONE-2	
6	8-EVEN-1	8 data bits          Parity even          1 stop bit
7	8-ODD-1	8 data bits          Parity odd          1 stop bit
8	8-NONE-1	Do not use with Modbus protocol
9	8-NONE-2	8 data bits          no Parity          2 stop bits

## Continuation "Parameter setting"

### SERIAL INIT

Not valid for Modbus communication

### SERIAL PROTOCOL

Not valid for Modbus communication

### SERIAL TIMER (S)

Not valid for Modbus communication

### SERIAL VALUE

Not valid for Modbus communication

### MODBUS

This parameter enables the Modbus protocol and determines the Modbus address.

	0	Do not use for Modbus protocol (Modbus disabled)
	1 ... 247	Modbus enabled: Serial interface is using Modbus RTU protocol The number set here determines the Modbus node address.

## 6.2.2. Modbus Communication

The following Modbus functions are available:

### Read Holding Registers and Write Multiple Registers

With the functions "Read Holding Registers" and "Write Multiple Registers" it is possible to access all registers of the device.

All variables (actual data) and status registers are mapped to Modbus Holding Registers. However, as all registers of the device are 32 bit registers but Modbus Holding registers are only 16 bit registers, each register of the device requires two Holding registers. (For this reason the use of Modbus function "Write Single Register" is not possible.)

It is only possible to access to one single register of the touchMATRIX® device by each read or write operation, therefore the "Quantity (or number) of registers" in the Modbus request must always be 2.

### Access to parameters

Holding Register 0x0000 / 0x0001 hex and following allow access to the device parameters.

The holding register numbers for a certain parameter can be calculated by the parameter # that can be found in the parameter table in the touchMatrix® device manual:

Holding Register low = (parameter #) x 2

Holding Register high = (parameter #) x 2 + 1

Example:

Access to parameter # 51 "PRESELECTION 1" by Holding Register 0x0066 and 0x0067 hex.



### Access to actual data

Holding Register 0x1000 / 0x1001 hex and following allow access to variables of the device (actual data registers):

- Holding Register 0x1000 / 0x1001 hex → Actual data with serial Code ":0" (Display value)
- Holding Register 0x1002 / 0x1003 hex → Actual data with serial Code ":1"
- Holding Register 0x1004 / 0x1005 hex → Actual data with serial Code ":2"
- Holding Register 0x1006 / 0x1007 hex → Actual data with serial Code ":3"
- etc.

### Access to status registers

Holding Register 0x2000 / 0x2001 hex and following allow access to status registers of the device:

- Holding Register 0x2000 / 0x2001 hex → Output Status (Ctrl. Out status, read only)
- Holding Register 0x2002 / 0x2003 hex → Serial Commands
- Holding Register 0x2004 / 0x2005 hex → External Command (Ctrl. In status, read only)
- Holding Register 0x2006 / 0x2007 hex → All Commands (read only)

### Read Coils and Write Single Coil

With the functions "Read Coils" and "Write Single Coil" it is possible to read and set/reset single commands:

Coil number	Serial code of command	Command	
0	54	Reset / Set	Reset/Set Value
1	55	Freeze Display	Freeze actual display value
2	56	Touch Disable	Disable touch screen
3	57	Clear Lock	Loosen locking of all outputs / relay
4	58	Clear Min/Max	Reset of the min. / max. values
5	59	Serial Print (do not use with Modbus)	Sending of serial data
6	60	Teach Preset 1	Current display value is stored as PRESELECTION 1
7	61	Teach Preset 2	Current display value is stored as PRESELECTION 2
8	62	Teach Preset 3	Current display value is stored as PRESELECTION 3
9	63	Teach Preset 4	Current display value is stored as PRESELECTION 4
10	64	Scroll Display	Display switching (see display in operation mode)
11	65	Clear Loop Time	Release all latched switching conditions
12	66	Start Preselection	The preselection starts
13	67	Activate Data (not required with Modbus)	The data is activated.
14	68	Store to EEPROM	Store to EEPROM
15	69	Testprogram (do not use with Modbus)	Testprogram (do not use with Modbus)

### 6.2.3. Diagnostics

The device supports the diagnostics subfunction 00 "Return Query Data". Other diagnostics functions are not available.

## 6.3. IO-Link Modul

This document is an additional description of the device AX350 with the option IO. A device with this additional option is required to use this device description. It contains important notes and information regarding IO-link communication data. In addition to general information about the IO link connection, it includes the parameter data of the device, the exchanged process data, as well as the implemented system commands and error codes.

### 6.3.1. Communications data

6 Parameters	Value
Communication speed	COM 3
Transmission rate	230,4 kbit/s
IO-Link Revision	V1.1
Cycle time	min. 3 ms
Portklasse	Class A  <b>Important:</b> The display device (IO-link device) must always be connected to a separate power supply (AC or DC)!

### 6.3.2. Features

Feature	Supported
Block parametrisation	Yes
Data Storage	Yes
SIO Mode	No

### 6.3.3. IO-Link interface

#### Usable IO-Link-Master

All IO-Link-masters, which support IO-link Standard v 1.1.

#### Connection of the IO-link interface

At terminal 34 (L-) and terminal 35 (L+) the supply voltage of the IO-link interface and at terminal 36 (c/q) the IO-link data line is connected to the port of the IO-link-master. Figure 1 shows the pin assignment of a standard M12 connection plug.

The display device (IO-link device) must also always be connected to a separate power supply (AC or DC).

Belegung		
	Pin 1	Clamp L+
	Pin 2	Not connected
	Pin 3	Clamp L-
	Pin 4	IO-Link data line, C/Q

Fig. 1: Pin assignment M12 connection plug

Pin	Wire color
1 (L+)	brown
2 (n.c.)	white
3 (L-)	blue
4 (C/Q)	black

### 6.3.4. Parameter data

ISDU Index	DPP1 Index	Name of the Parameter	Access	Length in bytes	Default Value	Range
<b>IDENTIFICATION MENU</b>						
	7	VendorID	R	2	980 / 0x 03D4	-
	8					
	9	Device ID	R	3	1265670 / 0x 135006	-
	10					
	11					
16		Vendor Name	R	12	motrona GmbH	-
17		Vendor Text	R	21	<a href="http://www.motrona.de">http://www.motrona.de</a>	-
18		Product Name	R	11	touchMATRIX®	-
19		Product ID	R	5	AX350	-
20		Product Text	R	35	display unit with IO-Link interface	-
21		Serial Number	R	1	-	-
22		Hardware Revision	R	7	350DX14	-
23		Firmware Revision	R	7	AX35006	-
24		Application Specific Tag	R/W	Max. 32	***	-
<b>GENERAL MENU</b>						
256		OPERATIONAL MODE	R/W	4	0	0..5
257		PIN PRESELECTION	R/W	4	0	0..9999
258		PIN PARAMETER	R/W	4	0	0..9999
259		BACK UP MEMORY	R/W	4	1	0..1
260		FACTORY SETTINGS	R/W	4	0	0..1
261		___	R/W	4	0	0..0
262		___	R/W	4	0	0..0
263		___	R/W	4	0	0..0
264		___	R/W	4	0	0..0
<b>IN 1 PROPERTIES</b>						
265		IN1 CONFIGURATION	R/W	4	0	0..2
266		IN1 START VALUE	R/W	4	0	-99999..99999
267		IN1 END VALUE	R/W	4	10000	-99999..99999
268		IN1 DECIMAL POINT	R/W	4	3	0..7
269		IN1 SCALE UNITS	R/W	4	0	0..29
270		IN1 SAMPLING TIME (ms)	R/W	4	10	1..60000
271		IN1 AVERAGE FILTER	R/W	4	0	0..4
272		IN1 OFFSET	R/W	4	0	-99999..99999
273		IN1 LINEARIZATION	R/W	4	0	0..2
274		IN1 TOTALIZATION	R/W	4	0	0..1
275		___	R/W	4	0	0..0
276		___	R/W	4	0	0..0
277		___	R/W	4	0	0..0

ISDU Index	DPP1 Index	Name of the Parameter	Access	Length in bytes	Default Value	Range
<b>IN 1 LINEARIZATION</b>						
278		IN1 LIN P1(X)	R/W	4	0	-99999999..99999999
279		IN1 LIN P1(Y)	R/W	4	0	-99999999..99999999
280		IN1 LIN P2(X)	R/W	4	0	-99999999..99999999
281		IN1 LIN P2(Y)	R/W	4	0	-99999999..99999999
282		IN1 LIN P3(X)	R/W	4	0	-99999999..99999999
283		IN1 LIN P3(Y)	R/W	4	0	-99999999..99999999
284		IN1 LIN P4(X)	R/W	4	0	-99999999..99999999
285		IN1 LIN P4(Y)	R/W	4	0	-99999999..99999999
286		IN1 LIN P5(X)	R/W	4	0	-99999999..99999999
287		IN1 LIN P5(Y)	R/W	4	0	-99999999..99999999
288		IN1 LIN P6(X)	R/W	4	0	-99999999..99999999
289		IN1 LIN P6(Y)	R/W	4	0	-99999999..99999999
290		IN1 LIN P7(X)	R/W	4	0	-99999999..99999999
291		IN1 LIN P7(Y)	R/W	4	0	-99999999..99999999
292		IN1 LIN P8(X)	R/W	4	0	-99999999..99999999
293		IN1 LIN P8(Y)	R/W	4	0	-99999999..99999999
294		IN1 LIN P9(X)	R/W	4	0	-99999999..99999999
295		IN1 LIN P9(Y)	R/W	4	0	-99999999..99999999
296		IN1 LIN P10(X)	R/W	4	0	-99999999..99999999
297		IN1 LIN P10(Y)	R/W	4	0	-99999999..99999999
298		IN1 LIN P11(X)	R/W	4	0	-99999999..99999999
299		IN1 LIN P11(Y)	R/W	4	0	-99999999..99999999
300		IN1 LIN P12(X)	R/W	4	0	-99999999..99999999
301		IN1 LIN P12(Y)	R/W	4	0	-99999999..99999999
302		IN1 LIN P13(X)	R/W	4	0	-99999999..99999999
303		IN1 LIN P13(Y)	R/W	4	0	-99999999..99999999

ISDU Index	DPP1 Index	Name of the Parameter	Access	Length in bytes	Default Value	Range
304		IN1 LIN P14(X)	R/W	4	0	-99999999..99999999
305		IN1 LIN P14(Y)	R/W	4	0	-99999999..99999999
306		IN1 LIN P15(X)	R/W	4	0	-99999999..99999999
307		IN1 LIN P15(Y)	R/W	4	0	-99999999..99999999
308		IN1 LIN P16(X)	R/W	4	0	-99999999..99999999
309		IN1 LIN P16(Y)	R/W	4	0	-99999999..99999999
310		IN1 LIN P17(X)	R/W	4	0	-99999999..99999999
311		IN1 LIN P17(Y)	R/W	4	0	-99999999..99999999
312		IN1 LIN P18(X)	R/W	4	0	-99999999..99999999
313		IN1 LIN P18(Y)	R/W	4	0	-99999999..99999999
314		IN1 LIN P19(X)	R/W	4	0	-99999999..99999999
315		IN1 LIN P19(Y)	R/W	4	0	-99999999..99999999
316		IN1 LIN P20(X)	R/W	4	0	-99999999..99999999
317		IN1 LIN P20(Y)	R/W	4	0	-99999999..99999999
318		IN1 LIN P21(X)	R/W	4	0	-99999999..99999999
319		IN1 LIN P21(Y)	R/W	4	0	-99999999..99999999
320		IN1 LIN P22(X)	R/W	4	0	-99999999..99999999
321		IN1 LIN P22(Y)	R/W	4	0	-99999999..99999999
322		IN1 LIN P23(X)	R/W	4	0	-99999999..99999999
323		IN1 LIN P23(Y)	R/W	4	0	-99999999..99999999
324		IN1 LIN P24(X)	R/W	4	0	-99999999..99999999
325		IN1 LIN P24(Y)	R/W	4	0	-99999999..99999999
<b>IN 1 TOTALIZATION</b>						
326		IN 1 TOT BASE	R/W	4	0	0..3
327		IN 1 TOT DIVIDER	R/W	4	0	0..3
328		IN 1 TOT DECIMAL POINT	R/W	4	0	0..7
329		IN 1 TOT SCALE UNITS	R/W	4	0	0..29
330		___	R/W	4	0	0..0
331		___	R/W	4	0	0..0
332		___	R/W	4	0	0..0

ISDU Index	DPP1 Index	Name of the Parameter	Access	Length in bytes	Default Value	Range
<b>IN 2 PROPERTIES</b>						
333		IN2 CONFIGURATION	R/W	4	0	0..2
334		IN2 START VALUE	R/W	4	0	-99999..99999
335		IN2 END VALUE	R/W	4	10000	-99999..99999
336		IN2 DECIMAL POINT	R/W	4	3	0..7
337		IN2 SCALE UNITS	R/W	4	0	0..29
338		IN2 SAMPLING TIME (ms)	R/W	4	10	1..60000
339		IN2 AVERAGE FILTER	R/W	4	0	0..4
340		IN2 OFFSET	R/W	4	0	-99999..99999
341		IN2 LINEARIZATION	R/W	4	0	0..2
342		IN2 TOTALIZATION	R/W	4	0	0..1
343		---	R/W	4	0	0..0
344		---	R/W	4	0	0..0
345		---	R/W	4	0	0..0
<b>IN 2 LINEARIZATION</b>						
346		IN2 LIN P1(X)	R/W	4	0	-99999999..99999999
347		IN2 LIN P1(Y)	R/W	4	0	-99999999..99999999
348		IN2 LIN P2(X)	R/W	4	0	-99999999..99999999
349		IN2 LIN P2(Y)	R/W	4	0	-99999999..99999999
350		IN2 LIN P3(X)	R/W	4	0	-99999999..99999999
351		IN2 LIN P3(Y)	R/W	4	0	-99999999..99999999
352		IN2 LIN P4(X)	R/W	4	0	-99999999..99999999
353		IN2 LIN P4(Y)	R/W	4	0	-99999999..99999999
354		IN2 LIN P5(X)	R/W	4	0	-99999999..99999999
355		IN2 LIN P5(Y)	R/W	4	0	-99999999..99999999
356		IN2 LIN P6(X)	R/W	4	0	-99999999..99999999
357		IN2 LIN P6(Y)	R/W	4	0	-99999999..99999999
358		IN2 LIN P7(X)	R/W	4	0	-99999999..99999999
359		IN2 LIN P7(Y)	R/W	4	0	-99999999..99999999
360		IN2 LIN P8(X)	R/W	4	0	-99999999..99999999
361		IN2 LIN P8(Y)	R/W	4	0	-99999999..99999999
362		IN2 LIN P9(X)	R/W	4	0	-99999999..99999999
363		IN2 LIN P9(Y)	R/W	4	0	-99999999..99999999

ISDU Index	DPP1 Index	Name of the Parameter	Access	Length in bytes	Default Value	Range
364		IN2 LIN P10(X)	R/W	4	0	-99999999..99999999
365		IN2 LIN P10(Y)	R/W	4	0	-99999999..99999999
366		IN2 LIN P11(X)	R/W	4	0	-99999999..99999999
367		IN2 LIN P11(Y)	R/W	4	0	-99999999..99999999
368		IN2 LIN P12(X)	R/W	4	0	-99999999..99999999
369		IN2 LIN P12(Y)	R/W	4	0	-99999999..99999999
370		IN2 LIN P13(X)	R/W	4	0	-99999999..99999999
371		IN2 LIN P13(Y)	R/W	4	0	-99999999..99999999
372		IN2 LIN P14(X)	R/W	4	0	-99999999..99999999
373		IN2 LIN P14(Y)	R/W	4	0	-99999999..99999999
374		IN2 LIN P15(X)	R/W	4	0	-99999999..99999999
375		IN2 LIN P15(Y)	R/W	4	0	-99999999..99999999
376		IN2 LIN P16(X)	R/W	4	0	-99999999..99999999
377		IN2 LIN P16(Y)	R/W	4	0	-99999999..99999999
378		IN2 LIN P17(X)	R/W	4	0	-99999999..99999999
379		IN2 LIN P17(Y)	R/W	4	0	-99999999..99999999
380		IN2 LIN P18(X)	R/W	4	0	-99999999..99999999
381		IN2 LIN P18(Y)	R/W	4	0	-99999999..99999999
382		IN2 LIN P19(X)	R/W	4	0	-99999999..99999999
383		IN2 LIN P19(Y)	R/W	4	0	-99999999..99999999
384		IN2 LIN P20(X)	R/W	4	0	-99999999..99999999
385		IN2 LIN P20(Y)	R/W	4	0	-99999999..99999999
386		IN2 LIN P21(X)	R/W	4	0	-99999999..99999999
387		IN2 LIN P21(Y)	R/W	4	0	-99999999..99999999
388		IN2 LIN P22(X)	R/W	4	0	-99999999..99999999
389		IN2 LIN P22(Y)	R/W	4	0	-99999999..99999999



ISDU Index	DPP1 Index	Name of the Parameter	Access	Length in bytes	Default Value	Range
390		IN2 LIN P23(X)	R/W	4	0	-99999999..99999999
391		IN2 LIN P23(Y)	R/W	4	0	-99999999..99999999
392		IN2 LIN P24(X)	R/W	4	0	-99999999..99999999
393		IN2 LIN P24(Y)	R/W	4	0	-99999999..99999999
<b>IN 2 TOTALIZATION</b>						
394		IN2 TOT BASE	R/W	4	0	0..3
395		IN2 TOT DIVIDER	R/W	4	0	0..3
396		IN2 TOT DECIMAL POINT	R/W	4	0	0..7
397		IN2 TOT SCALE UNITS	R/W	4	0	0..29
398		___	R/W	4	0	0..0
399		___	R/W	4	0	0..0
400		___	R/W	4	0	0..0
<b>LINKAGE PROPERTIES</b>						
401		LINKAGE FACTOR	R/W	4	1	-99999999..99999999
402		LINKAGE DIVIDER	R/W	4	1	-99999999..99999999
403		LINKAGE ADDITIVE VALUE	R/W	4	0	-99999999..99999999
404		LINKAGE DECIMAL POINT	R/W	4	0	0..7
405		LINKAGE SCALE UNITS	R/W	4	0	0..29
406		___	R/W	4	0	0..0
407		___	R/W	4	0	0..0
408		___	R/W	4	0	0..0
<b>IO LINK PROPERTIES</b>						
409		IN1 FACTOR	R/W	4	1	-99999999..99999999
410		IN1 DIVIDER	R/W	4	1	-99999999..99999999
411		IN1 ADDITIVE VALUE	R/W	4	0	-99999999..99999999
412		IN1 DECIMAL POINT	R/W	4	0	0..7
413		IN1 SCALE UNITS	R/W	4	0	0..29
414		IN2 FACTOR	R/W	4	1	-99999999..99999999
415		IN2 DIVIDER	R/W	4	1	-99999999..99999999
416		IN2 ADDITIVE VALUE	R/W	4	0	-99999999..99999999
417		IN2 DECIMAL POINT	R/W	4	0	0..7
418		IN2 SCALE UNITS	R/W	4	0	0..29
419		___	R/W	4	0	0..0
420		___	R/W	4	0	0..0
421		___	R/W	4	0	0..0
422		___	R/W	4	0	0..0

ISDU Index	DPP1 Index	Name of the Parameter	Access	Length in bytes	Default Value	Range
<b>PRESELECTION VALUES</b>						
423		PRESELECTION 1	R/W	4	1000	-99999999..99999999
424		PRESELECTION 2	R/W	4	2000	-99999999..99999999
425		PRESELECTION 3	R/W	4	3000	-99999999..99999999
426		PRESELECTION 4	R/W	4	4000	-99999999..99999999
427		---	R/W	4	0	0..0
428		---	R/W	4	0	0..0
<b>PRESELECTION 1 MENU</b>						
429		PRES1 SOURCE 1	R/W	4	0	0..11
430		PRES1 MODE 1	R/W	4	0	0..6
431		PRES1 HYSTERESIS 1	R/W	4	0	0..99999
432		PRES1 PULSE TIME 1 (ms)	R/W	4	0	0..60000
433		PRES1 OUTPUT TARGET 1	R/W	4	1	0..6
434		PRES1 OUTPUT POLARITY 1	R/W	4	0	0..1
435		PRES1 OUTPUT LOCK 1	R/W	4	0	0..1
436		PRES1 START UP DELAY 1(ms)	R/W	4	0	0..60000
437		PRES1 EVENT COLOR 1	R/W	4	0	0..3
438		---	R/W	4	0	0..0
439		---	R/W	4	0	0..0
<b>PRESELECTION 2 MENU</b>						
440		PRES2 SOURCE 2	R/W	4	0	0..11
441		PRES2 MODE 2	R/W	4	0	0..6
442		PRES2 HYSTERESIS 2	R/W	4	0	0..99999
443		PRES2 PULSE TIME 2 (ms)	R/W	4	0	0..60000
444		PRES2 OUTPUT TARGET 2	R/W	4	2	0..6
445		PRES2 OUTPUT POLARITY 2	R/W	4	0	0..1
446		PRES2 OUTPUT LOCK 2	R/W	4	0	0..1
447		PRES2 START UP DELAY 2 (ms)	R/W	4	0	0..60000
448		PRES2 EVENT COLOR 2	R/W	4	0	0..3
449		---	R/W	4	0	0..0
450		---	R/W	4	0	0..0
<b>PRESELECTION 3 MENU</b>						
451		PRES3 SOURCE 3	R/W	4	0	0..11
452		PRES3 MODE 3	R/W	4	0	0..6
453		PRES3 HYSTERESIS 3	R/W	4	0	0..99999
454		PRES3 PULSE TIME 3 (ms)	R/W	4	0	0..60000
455		PRES3 OUTPUT TARGET 3	R/W	4	3	0..6
456		PRES3 OUTPUT POLARITY 3	R/W	4	0	0..1
457		PRES3 OUTPUT LOCK 3	R/W	4	0	0..1
458		PRES3 START UP DELAY 3	R/W	4	0	0..1
459		PRES3 EVENT COLOR 3	R/W	4	0	0..3
460		---	R/W	4	0	0..0
461		---	R/W	4	0	0..0

ISDU Index	DPP1 Index	Name of the Parameter	Access	Length in bytes	Default Value	Range
<b>PRESELECTION 4 MENU</b>						
462		PRES4 SOURCE 4	R/W	4	0	0..11
463		PRES4 MODE 4	R/W	4	0	0..6
464		PRES4 HYSTERESIS 4	R/W	4	0	0..99999
465		PRES4 PULSE TIME 4 (ms)	R/W	4	0	0..60000
466		PRES4 OUTPUT TARGET 4	R/W	4	4	0..6
467		PRES4 OUTPUT POLARITY 4	R/W	4	0	0..1
468		PRES4 OUTPUT LOCK 4	R/W	4	0	0..1
469		PRES4 START UP DELAY 4	R/W	4	0	0..1
470		PRES4 EVENT COLOR 4	R/W	4	0	0..3
471		—	R/W	4	0	0..0
472		—	R/W	4	0	0..0
<b>SERIAL MENU</b>						
473		UNIT NUMBER	R/W	4	11	11..99
474		SERIAL BAUD RATE	R/W	4	0	0..2
475		SERIAL FORMAT	R/W	4	0	0..9
476		SERIAL INIT	R/W	4	0	0..1
477		SERIAL PROTOCOL	R/W	4	0	0..1
478		SERIAL TIMER	R/W	4	0	0..60000
479		SERIAL VALUE	R/W	4	0	0..9
480		MODBUS	R/W	4	0	0..247
481		—	R/W	4	0	0..0
<b>ANALOG OUT MENU</b>						
482		ANALOG SOURCE	R/W	4	0	0..11
483		ANALOG FORMAT	R/W	4	0	0..2
484		ANALOG START	R/W	4	0	-99999999..99999999
485		ANALOG END	R/W	4	10000	-99999999..99999999
486		ANALOG GAIN %	R/W	4	10000	0..11000
487		ANALOG OFFSET %	R/W	4	0	-9999..9999
488		—	R/W	4	0	0..0
489		—	R/W	4	0	0..0
<b>COMMAND MENU</b>						
490		INPUT 1 ACTION	R/W	4	0	0..28
491		INPUT 1 CONFIG.	R/W	4	2	0..3
492		INPUT 2 ACTION	R/W	4	0	0..28
493		INPUT 2 CONFIG.	R/W	4	2	0..3
494		INPUT 3 ACTION	R/W	4	0	0..28
495		INPUT 3 CONFIG.	R/W	4	2	0..3
496		—	R/W	4	0	0..0
497		—	R/W	4	0	0..0
498		—	R/W	4	0	0..0
499		—	R/W	4	0	0..0

ISDU Index	DPP1 Index	Name of the Parameter	Access	Length in bytes	Default Value	Range
<b>DISPLAY MENU</b>						
500		START DISPLAY	R/W	4	0	0..5
501		SOURCE SINGLE	R/W	4	0	0..11
502		SOURCE DUAL TOP	R/W	4	0	0..11
503		SOURCE DUAL DOWN	R/W	4	1	0..11
504		LARGE DISPLAY	R/W	4	0	0..6
505		SOURCE LARGE	R/W	4	0	0..11
506		COLOR	R/W	4	0	0..2
507		BRIGHTNESS (%)	R/W	4	80	10..100
508		CONTRAST	R/W	4	1	0..2
509		SCREEN SAVER (s)	R/W	4	0	0..9999
510		UP-DATE-TIME (ms)	R/W	4	100	5..9999
511		FONT	R/W	4	0	0..1
512		___	R/W	4	0	0..0
513		___	R/W	4	0	0..0
514		___	R/W	4	0	0..0

### 6.3.5. System Commands

A system command is a write-only parameter that causes an action in the device. To invoke the desired action, the corresponding value must be written to index 2, subindex 0. If the desired command is a static command (s), this command remains active until the corresponding value is written again to index 2, subindex 0. By resending the command, the action is terminated.

#### Predefined commands

Name	Index	Subindex	Value	Description of the action	Dynamic (d)/static (s)
RESTORE FACTORY SETTINGS	2	0	130	Reset all parameters to factory setting.	(d)

### 6.3.6. Application specific commands

Name	Index	Subindex	Value	Description of the action	Dynamic (d)/static (s)
TARA INPUT 1	2	0	160	Value of input 1 is stored as an offset from input 1.	(d)
TARA INPUT 2	2	0	161	Value of input 2 is stored as an offset from input 2.	(d)
TARA INPUT 1 + 2	2	0	162	Value of input 1 is stored as an offset from input 1, value of input 2 is stored as an offset from input 2	(d)
ADD TO TOTAL 1	2	0	163	Adds the current value from input 1 to INPUT 1 TOTAL.	(d)
ADD TO TOTAL 2	2	0	164	Adds the current value from input 2 to INPUT 2 TOTAL.	(d)
RESET TOTAL 1	2	0	165	Value of totalizator 1 is reset to 0.	(d)
RESET TOTAL 2	2	0	166	Value of totalizator 2 is reset to 0.	(d)
RESET TOTAL LINKAGE	2	0	167	Value of totalizator 1 and 2 are reset to 0.	(d)
TEACH PRESELECTION 1	2	0	168	Value (SOURCE 1) is saved as PRESELECTION 1.	(d)
TEACH PRESELECTION 2	2	0	169	Value (SOURCE 2) is saved as PRESELECTION 2.	(d)
TEACH PRESELECTION 3	2	0	170	Value (SOURCE 3) is saved as PRESELECTION 3.	(d)
TEACH PRESELECTION 4	2	0	171	Value (SOURCE 4) is saved as PRESELECTION 4.	(d)
SCROLL DISPLAY	2	0	172	Display switching.	(d)
SERIAL PRINT	2	0	173	Send serial data, see SERIAL VALUE.	(d)
SET TO RED	2	0	174	Display lights up red. The color can be changed by the event-dependent color switching in the PRESELECTION 1 ... 4 MENU	(d)
SET TO GREEN	2	0	175	Display lights up green. The color can be changed by the event-dependent color switching in the PRESELECTION 1 ... 4 MENU	(d)
SET TO YELLOW	2	0	176	Display lights up yellow. The color can be changed by the event-dependent color switching in the PRESELECTION 1 ... 4 MENU	(d)
CLEAR MIN/MAX VALUES	2	0	177	Reset of min/MAX values	(s)
CLEAR LOOP TIME	2	0	178	Loop time Reset	(d)
ACTIVATE DATA	2	0	179	N.A.	(d)
STORE EEPROM	2	0	180	Current parameter set is stored non-volatile in the EEPROM.	(d)
TESTPROGRAMM	2	0	181	Starts or stops the test program	(s)
FREEZE	2	0	182	Freeze the display value.	(s)
KEY LOCK	2	0	183	Keypad Lock: Touchscreen.	(s)

LOCK RELEASE	2	0	184	Self-locking of all outputs/relays.	(d)
--------------	---	---	-----	-------------------------------------	-----

### 6.3.7. IO-Link Prozessdaten

#### Process input (32 bytes)

View from the IO-link master!

Byte	Bit	Function	Logic
0	0	Output Status: Ctrl. Out 1	0 = OFF ; 1 = ON
	1	Output Status: Ctrl. Out 2	0 = OFF ; 1 = ON
	2	Output Status: Ctrl. Out 3	0 = OFF ; 1 = ON
	3	Output Status: Ctrl. Out 4	0 = OFF ; 1 = ON
	4	Output Status: Rel. 1	0 = OFF ; 1 = ON
	5	Output Status: Rel. 2	0 = OFF ; 1 = ON
	6	Output Status: Reserve	-
	7	Output Status: Reserve	-
1	8...15	Device status	0 = Device is operating properly; 2 = Out-of-Specification
2	16...23	Scale unit Linkage Totalisation	See chapter - Assignment table of the transferred unit!
3...6	24...55	Process value: Linkage Totalisation (incl. decimal point and sign)	-
7	56...63	Scale unit: Totalisation Input 2	See chapter - Assignment table of the transferred unit!
8...11	64...95	Process value: Totalisation Input 2 (incl. decimal point and sign)	-
12	96...103	Scale unit: Totalisation Input 1	See chapter - Assignment table of the transferred unit!
13...16	104...135	Process value: Totalisation Input 1 (incl. decimal point and sign)	-
17	136...143	Scale unit: Linkage Input 1+2	See chapter - Assignment table of the transferred unit!
18...21	144...175	Process value: Linkage Input 1+2 (incl. decimal point and sign)	-
22	176...183	Scale unit: Input 2	See chapter - Assignment table of the transferred unit!
23...26	184...215	Process value: Input 2 (incl. decimal point and sign)	-
27	216...223	Scale unit: Input 1	See chapter - Assignment table of the transferred unit!
28...31	224...255	Process value: Input 1 (incl. decimal point and sign)	-

## Process output data (8 Byte)

View from the IO-link master!

Byte	Bit	Function	Logic
0...3	0...31	IO-Link display value 1 (Data type: long - incl. sign)	-
4...7	32...63	IO-Link display value 2 (Data type: long - incl. sign)	-

## Assignment table of the transferred unit



Transferred value (decimal)	Appropriate scale unit	Related code „I0DD StandardUnitDefinitions1.1“
0	V	1240
1	mV	1243
2	A	1209
3	mA	1211
4	km/h	1064
5	mph	1065
6	feet/min	1070
7	inch/min	1069
8	g	1089
9	kg	1088
10	oz	1569
11	W	1186
12	kW	1190
13	VA	-
14	mm	1013
15	cm	1012
16	m	1010
17	inch	1019
18	feet	1018
19	C	1001
20	F	1002
21	K	1000
22	1/sec	1351
23	1/min	1352
24	1/h	1353
25	gal/min	1363
26	Pa	1130
27	kPa	1133
28	%	1342
29	Edit Unit (user defined unit)	-

### 6.3.8. Error type

Error code	Name	Description
32768 / 0x 8000	Application errors in the device-no details	Access was denied by the device. No detailed information is available.
32785 / 0x 8011	Index does not exist	Access to a non-existent index.
32786 / 0x 8012	Subindex does not exist	Access to a non-existent subindex..
32800 / 0x 8020	Service not available at this time	The parameter cannot be accessed at this moment. The device does not allow this in the current state.
32803 / 0x 8023	Access denied	Write access to a read-only parameter.
32816 / 0x 8030	Parameter value out of range	Parameter value is outside the allowed range of values.
32817 / 0x 8031	Parameter value greater than specified range	The written parameter value is greater than the specified value range.
32818 / 0x 8032	Parameter value less than specified range	The written parameter value is smaller than the specified value range.
32819 / 0x 8033	Parameter length too large	Parameter length is greater than allowed.
32820 / 0x 8034	Parameter length too small	Parameter length is less than allowed.
32821 / 0x 8035	Function not available	The device does not support the command.
32822 / 0x 8036	Function not available at this time	The command is not supported by the device in its current state.
32832 / 0x 8040	Invalid parameter set	Written single parameter value collides with the other parameter settings.
32833 / 0x 8041	Inconsistent parameter set	Inconsistencies were detected at the end of the block parameter transfer. The device plausibility check failed.
32898 / 0x 8082	Application not ready	Access was denied because the device is not ready.

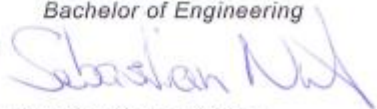

## 6.4. Declaration of Conformity IO-Link module

	
<b>MANUFACTURER'S DECLARATION OF CONFORMITY</b>	
<b>We:</b>	
<i>motrona GmbH</i> <i>Zeppelinstraße 16</i> <i>DE – 78244 Gottmadingen</i>	
<b>declare under our own responsibility that the product(s):</b>	
<i>touchMATRIX</i> <i>AX350/... /IO</i> <i>IO-Link Device</i>	
<b>to which this declaration refers conform to:</b>	
<input checked="" type="checkbox"/>	<ul style="list-style-type: none"><li>• IO-Link Interface and System Specification, V1.1, July 2013 (NOTE 1,2)</li><li>• IO Device Description, V1.1, August 2011</li></ul>
<input type="checkbox"/>	<ul style="list-style-type: none"><li>• IO-Link Interface and System Specification, V1.0, January 2009 (NOTE 1)</li><li>• IO Device Description, V1.0.1, March 2010</li></ul>
<b>The conformity tests are documented in the test report:</b>	
<ul style="list-style-type: none"><li>• <i>EMV Test_Report_Motrona_AX350_IO-Link.pdf</i></li><li>• <i>Physical Layer Test_Report_Motrona_AX350_IO-Link.pdf</i></li><li>• <i>Protocol Test Test_Report_Motrona_AX350_IO-Link.pdf</i></li></ul>	
<b>Issued at</b> <i>Gottmadingen, April 2018</i>	<b>Authorized signatory</b>
<b>Name:</b>	<b>Sebastian Nutz</b>
<b>Title:</b>	<i>Bachelor of Engineering</i>
<b>Signature:</b>	
Reproduction and all distribution without written authorization prohibited	

NOTE 1 Relevant Test specification is V1.1, July 2014

NOTE 2 Additional validity in Corrigendum Package 2015

Release April 2018

Published 13.04.2018

## 6.5. Display of scale units

SCALE UNITS																																																																										
This parameter defines the required engineering unit. This parameter does not affect the calculation of the display value. The number of decimal places must be defined with the parameter DECIMAL POINT.																																																																										
0	V	Default																																																																								
1	mV																																																																									
2	A																																																																									
3	mA																																																																									
4	km/h																																																																									
5	mph																																																																									
6	feet/min																																																																									
7	inch/min																																																																									
8	g																																																																									
9	kg																																																																									
10	oz																																																																									
11	W																																																																									
12	kW																																																																									
13	VA																																																																									
14	mm																																																																									
15	cm																																																																									
16	m																																																																									
17	inch																																																																									
18	feet																																																																									
19	C																																																																									
20	F																																																																									
21	K																																																																									
22	1/sec																																																																									
23	1/min																																																																									
24	1/h																																																																									
25	gal/min																																																																									
26	Pa																																																																									
27	kPa																																																																									
28	%																																																																									
29	<b>Edit Unit</b>	<p>A customized unit with up to 16 digits can be edited using this parameter. Pressing the "OK" button opens the Edit Unit Menu.</p> <p>A unit can be created using the arrow keys. (by pressing and holding the arrow keys the characters scroll fast).</p> <p>The "OK" button saves the Edit Unit Menu. The "C" button closes the Edit Unit Menu.</p> <table border="1"> <tbody> <tr> <td></td><td>!</td><td>"</td><td>#</td><td>\$</td><td>%</td><td>&amp;</td><td>'</td><td>(</td><td>)</td><td>*</td><td>+</td><td>,</td><td>-</td><td>.</td><td>/</td><td>0</td><td>1</td> </tr> <tr> <td>8</td><td>9</td><td>:</td><td>;</td><td>&lt;</td><td>=</td><td>&gt;</td><td>?</td><td>@</td><td>A</td><td>B</td><td>C</td><td>D</td><td>E</td><td>F</td><td>G</td><td>H</td><td>I</td> </tr> <tr> <td>P</td><td>Q</td><td>R</td><td>S</td><td>T</td><td>U</td><td>V</td><td>W</td><td>X</td><td>Y</td><td>Z</td><td>[</td><td>\</td><td>]</td><td>^</td><td>_</td><td>`</td><td>a</td> </tr> <tr> <td>h</td><td>i</td><td>j</td><td>k</td><td>l</td><td>m</td><td>n</td><td>o</td><td>p</td><td>q</td><td>r</td><td>s</td><td>t</td><td>u</td><td>v</td><td>w</td><td>x</td><td>y</td> </tr> </tbody> </table>		!	"	#	\$	%	&	'	(	)	*	+	,	-	.	/	0	1	8	9	:	;	<	=	>	?	@	A	B	C	D	E	F	G	H	I	P	Q	R	S	T	U	V	W	X	Y	Z	[	\	]	^	_	`	a	h	i	j	k	l	m	n	o	p	q	r	s	t	u	v	w	x	y
	!	"	#	\$	%	&	'	(	)	*	+	,	-	.	/	0	1																																																									
8	9	:	;	<	=	>	?	@	A	B	C	D	E	F	G	H	I																																																									
P	Q	R	S	T	U	V	W	X	Y	Z	[	\	]	^	_	`	a																																																									
h	i	j	k	l	m	n	o	p	q	r	s	t	u	v	w	x	y																																																									

## 6.6. Parameter / serial codes

6	Menu	Name	Serial Code	Value	Min	Max	Default
0	GENERAL MENU	OPERATIONAL MODE	0	0	0	5	0
1	GENERAL MENU	PIN PRESELECTION	1	0	0	9999	0
2	GENERAL MENU	PIN PARAMETER	2	0	0	9999	0
3	GENERAL MENU	BACK UP MEMORY	3	0	0	1	1
4	GENERAL MENU	FACTORY SETTINGS	4	0	0	1	0
5	GENERAL MENU	___	5	0	0	0	0
6	GENERAL MENU	___	6	0	0	0	0
7	GENERAL MENU	___	7	0	0	0	0
8	GENERAL MENU	___	8	0	0	0	0
9	IN 1 PROPERTIES	CONFIGURATION	9	0	0	2	0
10	IN 1 PROPERTIES	START VALUE	10	0	-99999	99999	0
11	IN 1 PROPERTIES	END VALUE	11	0	-99999	99999	10000
12	IN 1 PROPERTIES	DECIMAL POINT	12	0	0	7	3
13	IN 1 PROPERTIES	SCALE UNITS	13	0	0	29	0
14	IN 1 PROPERTIES	SAMPLING TIME (S)	14	0	1	60000	10
15	IN 1 PROPERTIES	AVERAGE FILTER	15	0	0	4	0
16	IN 1 PROPERTIES	OFFSET	16	0	-99999	99999	0
17	IN 1 PROPERTIES	LINEARIZATION	17	0	0	2	0
18	IN 1 PROPERTIES	TOTALIZATION	18	0	0	1	0
19	IN 1 PROPERTIES	___	19	0	0	0	0
20	IN 1 PROPERTIES	___	20	0	0	0	0
21	IN 1 PROPERTIES	___	21	0	0	0	0
22	IN 1 LINEARIZATION	P1(X)	A0	0	-99999999	99999999	0
23	IN 1 LINEARIZATION	P1(Y)	A1	0	-99999999	99999999	0
24	IN 1 LINEARIZATION	P2(X)	A2	0	-99999999	99999999	0
25	IN 1 LINEARIZATION	P2(Y)	A3	0	-99999999	99999999	0
26	IN 1 LINEARIZATION	P3(X)	A4	0	-99999999	99999999	0
27	IN 1 LINEARIZATION	P3(Y)	A5	0	-99999999	99999999	0
28	IN 1 LINEARIZATION	P4(X)	A6	0	-99999999	99999999	0
29	IN 1 LINEARIZATION	P4(Y)	A7	0	-99999999	99999999	0
30	IN 1 LINEARIZATION	P5(X)	A8	0	-99999999	99999999	0
31	IN 1 LINEARIZATION	P5(Y)	A9	0	-99999999	99999999	0
32	IN 1 LINEARIZATION	P6(X)	B0	0	-99999999	99999999	0
33	IN 1 LINEARIZATION	P6(Y)	B1	0	-99999999	99999999	0
34	IN 1 LINEARIZATION	P7(X)	B2	0	-99999999	99999999	0
35	IN 1 LINEARIZATION	P7(Y)	B3	0	-99999999	99999999	0
36	IN 1 LINEARIZATION	P8(X)	B4	0	-99999999	99999999	0
37	IN 1 LINEARIZATION	P8(Y)	B5	0	-99999999	99999999	0
38	IN 1 LINEARIZATION	P9(X)	B6	0	-99999999	99999999	0
39	IN 1 LINEARIZATION	P9(Y)	B7	0	-99999999	99999999	0
40	IN 1 LINEARIZATION	P10(X)	B8	0	-99999999	99999999	0
41	IN 1 LINEARIZATION	P10(Y)	B9	0	-99999999	99999999	0
42	IN 1 LINEARIZATION	P11(X)	C0	0	-99999999	99999999	0
43	IN 1 LINEARIZATION	P11(Y)	C1	0	-99999999	99999999	0
44	IN 1 LINEARIZATION	P12(X)	C2	0	-99999999	99999999	0
45	IN 1 LINEARIZATION	P12(Y)	C3	0	-99999999	99999999	0

Continuation „Parameterliste“:

#	Menu	Name	Serial Code	Value	Min	Max	Default
46	IN 1 LINEARIZATION	P13(X)	C4	0	-99999999	99999999	0
47	IN 1 LINEARIZATION	P13(Y)	C5	0	-99999999	99999999	0
48	IN 1 LINEARIZATION	P14(X)	C6	0	-99999999	99999999	0
49	IN 1 LINEARIZATION	P14(Y)	C7	0	-99999999	99999999	0
50	IN 1 LINEARIZATION	P15(X)	C8	0	-99999999	99999999	0
51	IN 1 LINEARIZATION	P15(Y)	C9	0	-99999999	99999999	0
52	IN 1 LINEARIZATION	P16(X)	D0	0	-99999999	99999999	0
53	IN 1 LINEARIZATION	P16(Y)	D1	0	-99999999	99999999	0
54	IN 1 LINEARIZATION	P17(X)	D2	0	-99999999	99999999	0
55	IN 1 LINEARIZATION	P17(Y)	D3	0	-99999999	99999999	0
56	IN 1 LINEARIZATION	P18(X)	D4	0	-99999999	99999999	0
57	IN 1 LINEARIZATION	P18(Y)	D5	0	-99999999	99999999	0
58	IN 1 LINEARIZATION	P19(X)	D6	0	-99999999	99999999	0
59	IN 1 LINEARIZATION	P19(Y)	D7	0	-99999999	99999999	0
60	IN 1 LINEARIZATION	P20(X)	D8	0	-99999999	99999999	0
61	IN 1 LINEARIZATION	P20(Y)	D9	0	-99999999	99999999	0
62	IN 1 LINEARIZATION	P21(X)	E0	0	-99999999	99999999	0
63	IN 1 LINEARIZATION	P21(Y)	E1	0	-99999999	99999999	0
64	IN 1 LINEARIZATION	P22(X)	E2	0	-99999999	99999999	0
65	IN 1 LINEARIZATION	P22(Y)	E3	0	-99999999	99999999	0
66	IN 1 LINEARIZATION	P23(X)	E4	0	-99999999	99999999	0
67	IN 1 LINEARIZATION	P23(Y)	E5	0	-99999999	99999999	0
68	IN 1 LINEARIZATION	P24(X)	E6	0	-99999999	99999999	0
69	IN 1 LINEARIZATION	P24(Y)	E7	0	-99999999	99999999	0
70	IN 1 TOTALIZATION	BASE	E8	0	0	3	0
71	IN 1 TOTALIZATION	DIVIDER	E9	0	0	3	0
72	IN 1 TOTALIZATION	DECIMAL POINT	F0	0	0	7	0
73	IN 1 TOTALIZATION	SCALE UNITS	F1	0	0	29	0
74	IN 1 TOTALIZATION	___	F2	0	0	0	0
75	IN 1 TOTALIZATION	___	F3	0	0	0	0
76	IN 1 TOTALIZATION	___	F4	0	0	0	0
77	IN 2 PROPERTIES	CONFIGURATION	F5	0	0	2	0
78	IN 2 PROPERTIES	START VALUE	F6	0	-99999	99999	0
79	IN 2 PROPERTIES	END VALUE	F7	0	-99999	99999	10000
80	IN 2 PROPERTIES	DECIMAL POINT	F8	0	0	7	3
81	IN 2 PROPERTIES	SCALE UNITS	F9	0	0	29	0
82	IN 2 PROPERTIES	SAMPLING TIME (S)	G0	0	1	60000	10
83	IN 2 PROPERTIES	AVERAGE FILTER	G1	0	0	4	0
84	IN 2 PROPERTIES	OFFSET	G2	0	-99999	99999	0
85	IN 2 PROPERTIES	LINEARIZATION	G3	0	0	2	0
86	IN 2 PROPERTIES	TOTALIZATION	G4	0	0	1	0
87	IN 2 PROPERTIES	___	G5	0	0	0	0
88	IN 2 PROPERTIES	___	G6	0	0	0	0
89	IN 2 PROPERTIES	___	G7	0	0	0	0

Continuation „Parameter“:

#	Menue	Name	Serial Code	Value	Min	Max	Default
90	IN 2 LINEARIZATION	P1(X)	G8	0	-99999999	99999999	0
91	IN 2 LINEARIZATION	P1(Y)	G9	0	-99999999	99999999	0
92	IN 2 LINEARIZATION	P2(X)	H0	0	-99999999	99999999	0
93	IN 2 LINEARIZATION	P2(Y)	H1	0	-99999999	99999999	0
94	IN 2 LINEARIZATION	P3(X)	H2	0	-99999999	99999999	0
95	IN 2 LINEARIZATION	P3(Y)	H3	0	-99999999	99999999	0
96	IN 2 LINEARIZATION	P4(X)	H4	0	-99999999	99999999	0
97	IN 2 LINEARIZATION	P4(Y)	H5	0	-99999999	99999999	0
98	IN 2 LINEARIZATION	P5(X)	H6	0	-99999999	99999999	0
99	IN 2 LINEARIZATION	P5(Y)	H7	0	-99999999	99999999	0
100	IN 2 LINEARIZATION	P6(X)	H8	0	-99999999	99999999	0
101	IN 2 LINEARIZATION	P6(Y)	H9	0	-99999999	99999999	0
102	IN 2 LINEARIZATION	P7(X)	I0	0	-99999999	99999999	0
103	IN 2 LINEARIZATION	P7(Y)	I1	0	-99999999	99999999	0
104	IN 2 LINEARIZATION	P8(X)	I2	0	-99999999	99999999	0
105	IN 2 LINEARIZATION	P8(Y)	I3	0	-99999999	99999999	0
106	IN 2 LINEARIZATION	P9(X)	I4	0	-99999999	99999999	0
107	IN 2 LINEARIZATION	P9(Y)	I5	0	-99999999	99999999	0
108	IN 2 LINEARIZATION	P10(X)	I6	0	-99999999	99999999	0
109	IN 2 LINEARIZATION	P10(Y)	I7	0	-99999999	99999999	0
110	IN 2 LINEARIZATION	P11(X)	I8	0	-99999999	99999999	0
111	IN 2 LINEARIZATION	P11(Y)	I9	0	-99999999	99999999	0
112	IN 2 LINEARIZATION	P12(X)	J0	0	-99999999	99999999	0
113	IN 2 LINEARIZATION	P12(Y)	J1	0	-99999999	99999999	0
114	IN 2 LINEARIZATION	P13(X)	J2	0	-99999999	99999999	0
115	IN 2 LINEARIZATION	P13(Y)	J3	0	-99999999	99999999	0
116	IN 2 LINEARIZATION	P14(X)	J4	0	-99999999	99999999	0
117	IN 2 LINEARIZATION	P14(Y)	J5	0	-99999999	99999999	0
118	IN 2 LINEARIZATION	P15(X)	J6	0	-99999999	99999999	0
119	IN 2 LINEARIZATION	P15(Y)	J7	0	-99999999	99999999	0
120	IN 2 LINEARIZATION	P16(X)	J8	0	-99999999	99999999	0
121	IN 2 LINEARIZATION	P16(Y)	J9	0	-99999999	99999999	0
122	IN 2 LINEARIZATION	P17(X)	K0	0	-99999999	99999999	0
123	IN 2 LINEARIZATION	P17(Y)	K1	0	-99999999	99999999	0
124	IN 2 LINEARIZATION	P18(X)	K2	0	-99999999	99999999	0
125	IN 2 LINEARIZATION	P18(Y)	K3	0	-99999999	99999999	0
126	IN 2 LINEARIZATION	P19(X)	K4	0	-99999999	99999999	0
127	IN 2 LINEARIZATION	P19(Y)	K5	0	-99999999	99999999	0
128	IN 2 LINEARIZATION	P20(X)	K6	0	-99999999	99999999	0
129	IN 2 LINEARIZATION	P20(Y)	K7	0	-99999999	99999999	0
130	IN 2 LINEARIZATION	P21(X)	K8	0	-99999999	99999999	0
131	IN 2 LINEARIZATION	P21(Y)	K9	0	-99999999	99999999	0
132	IN 2 LINEARIZATION	P22(X)	L0	0	-99999999	99999999	0
133	IN 2 LINEARIZATION	P22(Y)	L1	0	-99999999	99999999	0
134	IN 2 LINEARIZATION	P23(X)	L2	0	-99999999	99999999	0
135	IN 2 LINEARIZATION	P23(Y)	L3	0	-99999999	99999999	0
136	IN 2 LINEARIZATION	P24(X)	L4	0	-99999999	99999999	0
137	IN 2 LINEARIZATION	P24(Y)	L5	0	-99999999	99999999	0

Continuation „Parameter“

#	Menu	Name	Serial Code	Value	Min	Max	Default
138	IN 2 TOTALIZATION	BASE	L6	0	0	3	0
139	IN 2 TOTALIZATION	DIVIDER	L7	0	0	3	0
140	IN 2 TOTALIZATION	DECIMAL POINT	L8	0	0	7	0
141	IN 2 TOTALIZATION	SCALE UNITS	L9	0	0	29	0
142	IN 2 TOTALIZATION	___	M0	0	0	0	0
143	IN 2 TOTALIZATION	___	M1	0	0	0	0
144	IN 2 TOTALIZATION	___	M2	0	0	0	0
145	LINKAGE PROPERTIES	FACTOR	M3	0	-99999999	99999999	1
146	LINKAGE PROPERTIES	DIVIDER	M4	0	-99999999	99999999	1
147	LINKAGE PROPERTIES	ADDITIVE VALUE	M5	0	-99999999	99999999	0
148	LINKAGE PROPERTIES	DECIMAL POINT	M6	0	0	7	0
149	LINKAGE PROPERTIES	SCALE UNITS	M7	0	0	29	0
150	LINKAGE PROPERTIES	___	M8	0	0	0	0
151	LINKAGE PROPERTIES	___	M9	0	0	0	0
152	LINKAGE PROPERTIES	___	N0	0	0	0	0
153	IO LINK PROPERTIES	IN1 FACTOR	N1	0	-99999999	99999999	1
154	IO LINK PROPERTIES	IN1 DEVIDER	N2	0	-99999999	99999999	1
155	IO LINK PROPERTIES	IN1 ADDITIVE VALUE	N3	0	-99999999	99999999	0
156	IO LINK PROPERTIES	IN1 DECIMAL POINT	N4	0	0	7	0
157	IO LINK PROPERTIES	IN1 SCALE UNITS	N5	0	0	29	0
158	IO LINK PROPERTIES	IN2 FACTOR	N6	0	-99999999	99999999	1
159	IO LINK PROPERTIES	IN2 DEVIDER	N7	0	-99999999	99999999	1
160	IO LINK PROPERTIES	IN2 ADDITIVE VALUE	N8	0	-99999999	99999999	0
161	IO LINK PROPERTIES	IN2 DECIMAL POINT	N9	0	0	7	0
162	IO LINK PROPERTIES	IN2 SCALE UNITS	00	0	0	29	0
163	IO LINK PROPERTIES	___	01	0	0	0	0
164	IO LINK PROPERTIES	___	02	0	0	0	0
165	IO LINK PROPERTIES	___	03	0	0	0	0
166	IO LINK PROPERTIES	___	04	0	0	0	0
167	PRESELECTION VALUES	PRESELECTION 1	05	0	-99999999	99999999	1000
168	PRESELECTION VALUES	PRESELECTION 2	06	0	-99999999	99999999	2000
169	PRESELECTION VALUES	PRESELECTION 3	07	0	-99999999	99999999	3000
170	PRESELECTION VALUES	PRESELECTION 4	08	0	-99999999	99999999	4000
171	PRESELECTION VALUES	___	09	0	0	0	0
172	PRESELECTION VALUES	___	P0	0	0	0	0
173	PRESELECTION 1 MENU	SOURCE 1	P1	0	0	11	0
174	PRESELECTION 1 MENU	MODE 1	P2	0	0	6	0
175	PRESELECTION 1 MENU	HYSTERESIS 1	P3	0	0	99999	0
176	PRESELECTION 1 MENU	PULSE TIME 1	P4	0	0	60000	0
177	PRESELECTION 1 MENU	OUTPUT TARGET 1	P5	0	0	6	1
178	PRESELECTION 1 MENU	OUTPUT POLARITY 1	P6	0	0	1	0
179	PRESELECTION 1 MENU	OUTPUT LOCK 1	P7	0	0	1	0
180	PRESELECTION 1 MENU	START UP DELAY 1	P8	0	0	60000	0
181	PRESELECTION 1 MENU	EVENT COLOR 1	P9	0	0	3	0
182	PRESELECTION 1 MENU	___	Q0	0	0	0	0
183	PRESELECTION 1 MENU	___	Q1	0	0	0	0

## Continuation „Parameter“

#	Menue	Name	Serial Code	Value	Min	Max	Default
184	PRESELECTION 2 MENU	SOURCE 2	Q2	0	0	11	0
185	PRESELECTION 2 MENU	MODE 2	Q3	0	0	6	0
186	PRESELECTION 2 MENU	HYSTERESIS 2	Q4	0	0	99999	0
187	PRESELECTION 2 MENU	PULSE TIME 2	Q5	0	0	60000	0
188	PRESELECTION 2 MENU	OUTPUT TARGET 2	Q6	0	0	6	2
189	PRESELECTION 2 MENU	OUTPUT POLARITY 2	Q7	0	0	1	0
190	PRESELECTION 2 MENU	OUTPUT LOCK 2	Q8	0	0	1	0
191	PRESELECTION 2 MENU	START UP DELAY 2	Q9	0	0	60000	0
192	PRESELECTION 2 MENU	EVENT COLOR 2	R0	0	0	3	0
193	PRESELECTION 2 MENU	__	R1	0	0	0	0
194	PRESELECTION 2 MENU	__	R2	0	0	0	0
195	PRESELECTION 3 MENU	SOURCE 3	R3	0	0	11	0
196	PRESELECTION 3 MENU	MODE 3	R4	0	0	6	0
197	PRESELECTION 3 MENU	HYSTERESIS 3	R5	0	0	99999	0
198	PRESELECTION 3 MENU	PULSE TIME 3	R6	0	0	60000	0
199	PRESELECTION 3 MENU	OUTPUT TARGET 3	R7	0	0	6	3
200	PRESELECTION 3 MENU	OUTPUT POLARITY 3	R8	0	0	1	0
201	PRESELECTION 3 MENU	OUTPUT LOCK 3	R9	0	0	1	0
202	PRESELECTION 3 MENU	START UP DELAY 3	S0	0	0	1	0
203	PRESELECTION 3 MENU	EVENT COLOR 3	90	0	0	3	0
204	PRESELECTION 3 MENU	__	91	0	0	0	0
205	PRESELECTION 3 MENU	__	92	0	0	0	0
206	PRESELECTION 4 MENU	SOURCE 4	9~	0	0	11	0
207	PRESELECTION 4 MENU	MODE 4	S1	0	0	6	0
208	PRESELECTION 4 MENU	HYSTERESIS 4	S2	0	0	99999	0
209	PRESELECTION 4 MENU	PULSE TIME 4	S3	0	0	60000	0
210	PRESELECTION 4 MENU	OUTPUT TARGET 4	S4	0	0	6	4
211	PRESELECTION 4 MENU	OUTPUT POLARITY 4	S5	0	0	1	0
212	PRESELECTION 4 MENU	OUTPUT LOCK 4	S6	0	0	1	0
213	PRESELECTION 4 MENU	START UP DELAY 4	S7	0	0	1	0
214	PRESELECTION 4 MENU	EVENT COLOR 4	S8	0	0	3	0
215	PRESELECTION 4 MENU	__	S9	0	0	0	0
216	PRESELECTION 4 MENU	__	T0	0	0	0	0
217	SERIAL MENU	UNIT NUMBER	T1	0	11	99	11
218	SERIAL MENU	SERIAL BAUD RATE	T2	0	0	2	0
219	SERIAL MENU	SERIAL FORMAT	T3	0	0	9	0
220	SERIAL MENU	SERIAL INIT	T4	0	0	1	0
221	SERIAL MENU	SERIAL PROTOCOL	T5	0	0	1	0
222	SERIAL MENU	SERIAL TIMER	T6	0	0	60000	0
223	SERIAL MENU	SERIAL VALUE	T7	0	0	9	0
224	SERIAL MENU	MODBUS	T8	0	0	0	247
225	SERIAL MENU	__	T9	0	0	0	0

## Continuation „Parameter“

#	Menue	Name	Serial Code	Value	Min	Max	Default
226	ANALOG OUT MENU	ANALOG SOURCE	U0	0	0	11	0
227	ANALOG OUT MENU	ANALOG FORMAT	U1	0	0	2	0
228	ANALOG OUT MENU	ANALOG START	U2	0	-99999999	99999999	0
229	ANALOG OUT MENU	ANALOG END	U3	0	-99999999	99999999	10000
230	ANALOG OUT MENU	ANALOG GAIN %	U4	0	0	11000	10000
231	ANALOG OUT MENU	ANALOG OFFSET %	U5	0	-9999	9999	0
232	ANALOG OUT MENU	___	U6	0	0	0	0
233	ANALOG OUT MENU	___	U7	0	0	0	0
234	COMMAND MENU	INPUT 1 ACTION	U8	0	0	28	0
235	COMMAND MENU	INPUT 1 CONFIG.	U9	0	0	3	2
236	COMMAND MENU	INPUT 2 ACTION	V0	0	0	28	0
237	COMMAND MENU	INPUT 2 CONFIG.	V1	0	0	3	2
238	COMMAND MENU	INPUT 3 ACTION	V2	0	0	28	0
239	COMMAND MENU	INPUT 3 CONFIG.	V3	0	0	3	2
240	COMMAND MENU	___	V4	0	0	0	0
241	COMMAND MENU	___	V5	0	0	0	0
242	COMMAND MENU	___	V6	0	0	0	0
243	COMMAND MENU	___	V7	0	0	0	0
244	DISPLAY MENU	START DISPLAY	V8	0	0	5	0
245	DISPLAY MENU	SOURCE SINGLE	V9	0	0	11	0
246	DISPLAY MENU	SOURCE DUAL TOP	W0	0	0	11	0
247	DISPLAY MENU	SOURCE DUAL DOWN	W1	0	0	11	1
248	DISPLAY MENU	LARGE DISPLAY	W2	0	0	6	0
249	DISPLAY MENU	SOURCE LARGE	W3	0	0	11	0
250	DISPLAY MENU	COLOR	W4	0	0	2	0
251	DISPLAY MENU	BRIGHTNESS	W5	0	10	100	80
252	DISPLAY MENU	CONTRAST	W6	0	0	2	1
253	DISPLAY MENU	SCREEN SAVER	W7	0	0	9999	0
254	DISPLAY MENU	UP-DATE-TIME	W8	0	5	9999	100
255	DISPLAY MENU	FONT	W9	0	0	1	0
256	DISPLAY MENU	___	a0	0	0	0	0



Serial codes of commands:

Serial Code	Command
54	TARA INPUT 1
55	TARA INPUT 2
56	TARA INPUT 1 + 2
57	RESET TOTAL 1
58	RESET TOTAL 2
59	RESET TOTAL LINKAGE
60	TEACH PRESELECTION 1
61	TEACH PRESELECTION 2
62	TEACH PRESELECTION 3
63	TEACH PRESELECTION 4
64	SCROLL DISPLAY
65	CLEAR MIN/MAX VALUES
66	CLEAR LOOP TIME
67	ACTIVATE DATA
68	STORE EEPROM
69	TESTPROGRAMM

## 6.7. Linearization

The linearization function of this unit allows converting a linear input signal into a non-linear developing (or vice versa). There are 24 programmable x/y coordinates available for input 1 and input 2, which can be set in any desired distance over the full conversion range. Between two coordinates, the unit uses linear interpolation. Therefore it is advisable to use more coordinates in a range with strong curves and only a few coordinates where the curvature is less.

To specify an individual linearization curve, the parameter LINEARISAZATION MODE must be set to either 1 QUADRANT or 4 QUADRANT (see following diagram).

The parameters P1(X) to P24(X) are used to specify the coordinates on the x-axis. These are the measuring values that the unit normally would generate according to the actual input signal.

Now enter the attached values to parameter P1(Y) to P24(Y). These are the values that the unit will generate instead of the x- values, i.e. P5(Y) replaces P5(X) etc.

The X-Coordinates must use continuously increasing settings, i.e. P1(X) must have the lowest and P24(X) must have the highest setting. If the measured value is bigger than the last defined X-value, the corresponding Y-value is displayed.

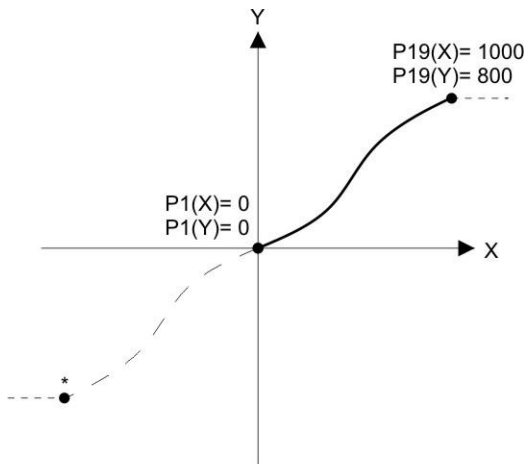

Example: Linearization Mode: 1 Quadrant

\* Linearization is point symmetric to 1. Quadrant

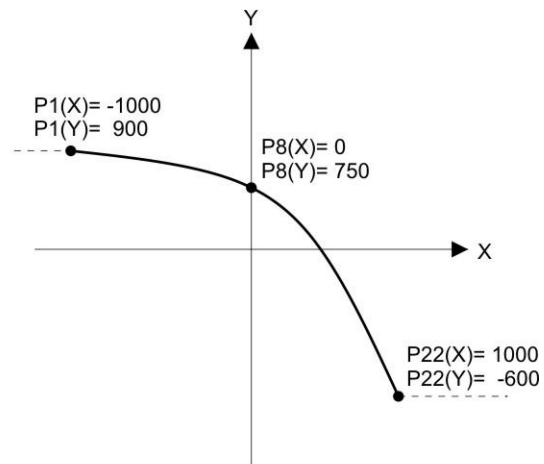

Example: Linearization Mode: 4 Quadrant

### Mode: 1 Quadrant:

P1(X) must be set to zero. Linearization is only defined in the positive range and the negative range will be mirrored symmetric to central point.

### Mode: 4 Quadrant:

P1(X) can also be set to a negative value. If the measured value is smaller than P1(X), P1(Y) is displayed.

Application Example:

We like to display the filling quantity (volume) of a tank as shown below, with use of a pressure sensor mounted to the bottom of the tank. With this application the analogue pressure signal is proportional to the filling level, but not to the filling quantity.

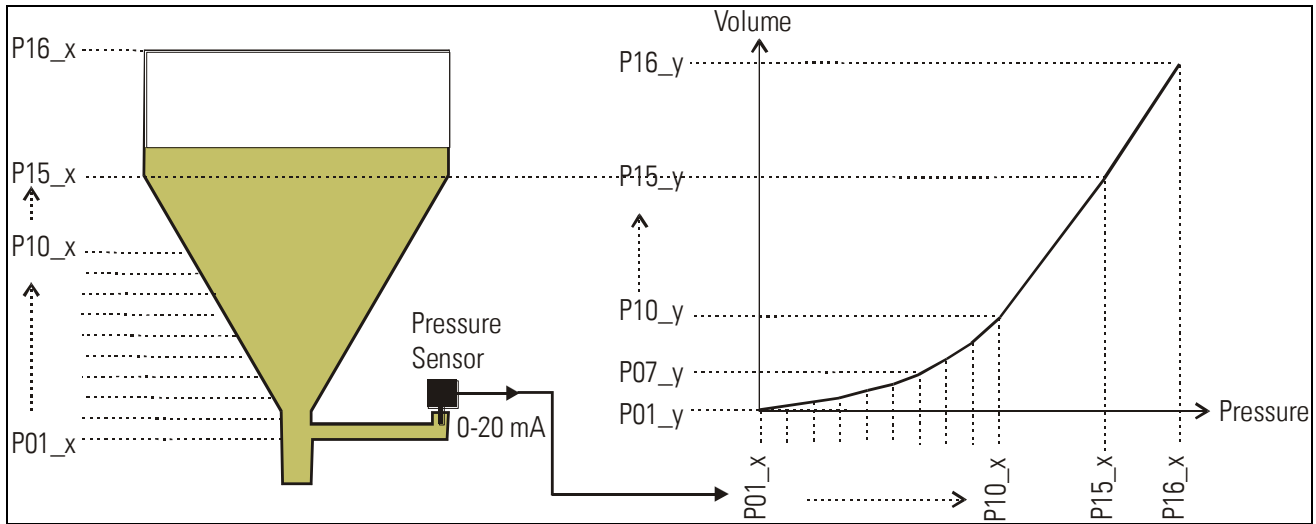

To solve the problem, we divide the non-linear part of the tank into 14 parts. We enter the expected display values of the pressure sensor to registers P01\_x to P15\_x. For the linear part of the tank it is sufficient to store the final pressure value to register P16\_x. Now we can easily calculate the appropriate filling quantities and enter these values to the registers P01\_y to P16\_y.

## 6.8. Dimensions

Dimension in mm [inch]

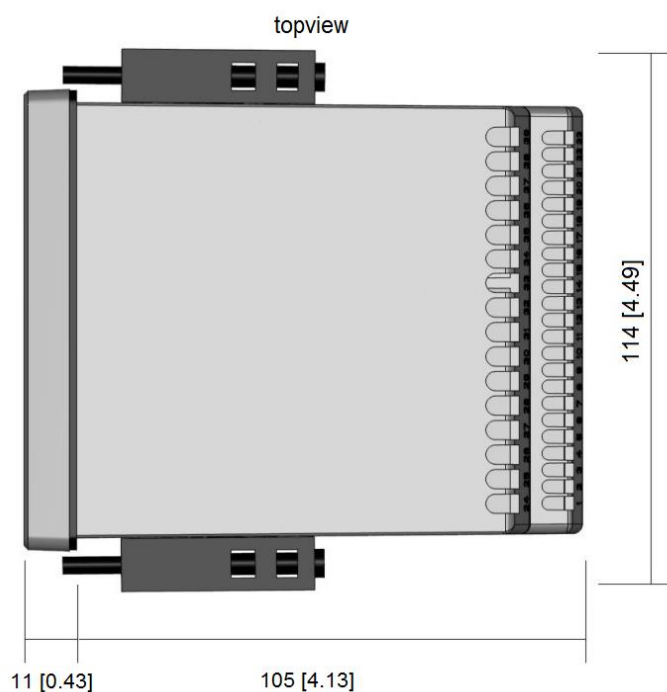
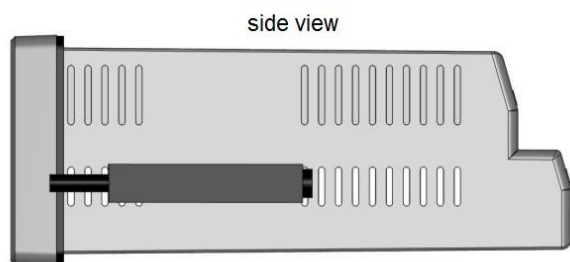
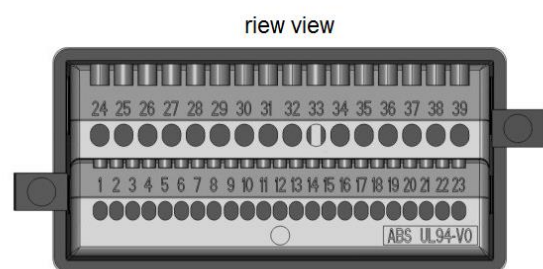
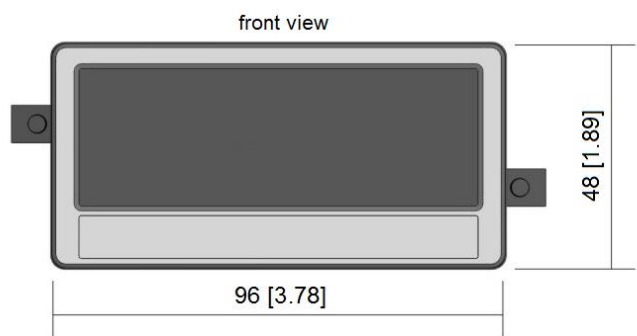

## 6.9. Technical specifications

Technical Specifications:		
<b>Connections:</b>	Connector type:	screw terminal, 1.5 mm <sup>2</sup> / AWG 16
<b>Power supply (DC):</b>	Input voltage:	18 ... 30 VDC
	Protection circuit:	reverse polarity protection
	Consumption:	approx. 100 mA (unloaded)
	Fuse protection:	extern: T 0,5A
<b>Power supply (AC):</b> (Option AC)	Input voltage:	115...230 VAC, 50...60 Hz)
	Power consumption:	approx. 3 VA (unloaded)
	Fuse protection:	extern: T 0,1 A
<b>Encoder supply:</b>	DC version:	approx. 1 V lower than the power supply voltage
	Output current:	max. 250 mA
	AC version (AC350):	approx. 24 V (± 15%)
	Output current:	150 mA until 45°C / 80 mA by more than 45°C
<b>Reference output:</b>	Output voltage:	10 V
	Accuracy:	± 0.1 %
	Load:	max. 10 mA
<b>Analog inputs:</b>	Number of inputs:	2
	Configuration:	current or voltage operation
	Voltage input:	-10 ... +10 V (Ri ≈ 50 kOhm)
	Current input:	0 ... 20 mA / 4 ... 20 mA (Ri ≈ 100 Ohm)
	Resolution:	16 bit
	Accuracy:	± 0,1 %
<b>Control inputs:</b>	Number of inputs:	3
	Format:	HTL, PNP (Low 0 ... 3 V, High 9 ... 30 V)
	Frequency:	max. 10 kHz
	Load:	max. 2 mA / Ri > 15 kOhm / 470 pF
<b>Analog output:</b> (Option AO/AR)	Configuration:	current or voltage operation
	Voltage output:	-10...+10 V (max. 2 mA)
	Current output:	0/4... 20 mA (burden: max. 270 Ohm)
	Resolution:	16 Bit
	Accuracy:	± 0,1 %
	Reaction time:	< 150 ms
<b>Control outputs:</b> (Option AO/AR/CO/CR)	Number of outputs:	4
	Format / level:	5 ... 30 V (depends on the Com+ voltage), PNP
	Output current:	max. 200 mA
	Reaction time:	< 1 ms
<b>Relay outputs:</b> (Option RL)	Number of outputs:	2
	Configuration:	potential free changeovers
	AC-Switching capacity:	max. 250 VAC / 3 A / 750 VA
	DC-Switching capacity::	max. 150 VDC / 2 A / 50 W
	Reaction time:	< 20 ms
<b>Serial interface:</b> (Option AO/AR/CO/CR)	Format (Option AO/CO):	RS232
	Format (Option AR/CR)	RS485
	Baudrate:	9600, 19200 or 38400 baud
<b>IO-Link:</b> (Option IO)	Module / Revision:	Device / V1.1
	Bitrate:	COM 3
	Port Class:	Typ A

Continuation "Technical specifications"

<b>Display:</b>	Type: Display range: Digit height: Color: Operation:	Graphic LCD with backlight 8 Dekaden plus Vorzeichen (-99999999 ... 99999999) 13 mm red/ green / yellow (switchable) resistive touchscreen
<b>Housing:</b>	Material: Mounting: Dimensions (w x h x d): Cut out (w x h): Protection class: Weight:	ABS, UL 94 V-0 panel 96 x 48 x 116 mm / 3.78 x 1.89 x 4.56 inch 91 x 43 mm / 3.58 x 1.69 inch IP65 (front), IP20 (rear) approx. 200 g
<b>Ambient temperature:</b>	Operation: Storage:	-20 °C ... +60 °C resp. -4 ... 140 °F -25 °C ... +70 °C resp. -13 ... 158 °F
<b>Conformity and standards:</b>	EMC 2014/30/EU:  LV 2014/35/EU: (Only for option AC and RL) RoHS ( II ) 2011/65/EU RoHS (III) 2015/863:	EN 61000-6-2, EN 61000-6-3, EN 61000-6-4, EN 61362-1 EN 61010-1   EN IEC 63000