



■ Features

- 4" x 2" miniature size
- 48Vdc input (20~55Vdc)
- 3-phase switches with sensors in one unit for external control (control board VFD-CB sold separately)
- High peak current up to 200% and 5 seconds
- Fanless design for silent operation and long lifetime
- Protections : Short circuit / OCP
- Internal sensors feed out for control :
Current sensor - motor torque control
DC bus voltage sensor - OVP/UVP
Temperature sensor - OTP
- -30~+70°C wider operating temperature
- Suitable for 3-phase motor drive (e.g. BLDC, Induction motor, SynRM)
- 3 years warranty

■ Applications

- HVAC
- Fan
- Water/Air pump
- Power tools
- Conveyor
- Automatic door
- Fitness equipment

■ GTIN CODE

MW Search: <https://www.meanwell.com/serviceGTIN.aspx>

■ Description

The VFD-150P-48 is an universal variable frequency drive power module providing integrated 3-phase switches with gate drivers and basic VFD sensors such as three phase output current and temperature sensors. This product can be implemented for a three phase motor drive solution by coordinating with an external motor drive controller in logic level and analog I/O. The three phase motor output is supported up to 55Vdc with 200% peak current capability. The compact size of 4"x2"and fanless design makes it easy to be integrated into all kinds of motor system. The VFD-150P-48 is suitable for three-phase motor drive, such as BLDC, Induction motor, and SynRM applications.

■ Model Encoding

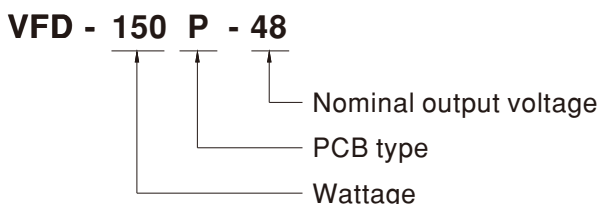

**SPECIFICATION**

MODEL NO.		VFD-150P-48		
OUTPUT (Note1,2,3,4)	VOLTAGE RANGE(UVW)	55V Max, line-to-line voltage 0~34V adjusted with modulated PWM, suitable for 48V class motor.		
	CURRENT	Rated	4.3A	
		Peak	8.6A for 5 seconds	
	RATED POWER	150W		
	EFFICIENCY	93%		
	PMW FREQUENCY	2.5KHz ~ 15KHz		
INPUT	RATED INPUT VOLTAGE	20 ~ 55VDC		
	RATED INPUT CURRENT	3.5A /48VDC Typ.		
FUNCTION (Note.5)	3-PHASE PWM CONTROL	PWM control signal to gate driver for IGBTs. (CN93, PIN8~13) 3.3V TTL/CMOS input : High (>2.7V) : IGBT ON ; Low (<0.4V) : IGBT OFF		
	3- PHASE PWM CONTROL	Built-in 6mΩ low-side shunt resistor (each phase), (CN93, PIN4~6)		
	DC BUS VOLTAGE SENSOR	DC BUS voltage sensor output(DC+ sensor, CN93 of PIN1): 2.5V@DC BUS 48V		
	THERMAL SENSOR	Built-in 10KΩ NTC for sensing IGBTs operating temperature. (TSM2A103F34D1R (Thinking Electronic), PIN3 of CN93)		
	FAULT SIGNAL	Inverter fault signal(Short circuit/OCP, CN93,PIN7). 3.3V TTL/CMOS output : Normal High (>3V) ; Abnormal : Low (<0.5V)		
	AUXILIARY POWER	Non-isolated 15V output power for external control board (CN93, PIN14 to PIN2) 15V @ 0.2A ; Tolerance ±0.5V, Ripple 1Vp-p max		
PROTECTION	SHORT CIRCUIT	Protection type : Shut down o/p voltage, re-power on to recover		
ENVIRONMENT	WORKING TEMP.	-30 ~ +70°C (Refer to "Dreating Curve")		
	WORKING HUMIDITY	20 ~ 90% RH non-condensing		
	STORAGE TEMP., HUMIDITY	-40 ~ +85°C, 10 ~ 95% RH non-condensing		
	VIBRATION	10 ~ 500Hz, 2G 10min./1cycle, period for 60min. each along X, Y, Z axes		
SAFETY & EMC	SAFETY STANDARDS	CB IEC61800-5-1,TUV/BS EN/EN61800-5-1,EAC TP TC004 approved		
	EMC EMISSION	Parameter	Standard	Test Level / Note
		Conducted	BS EN/EN IEC61800-3	Class A, C2
		Radiated	BS EN/EN IEC61800-3	Class A, C2
	EMC IMMUNITY	BS EN/EN IEC61800-3, second environment		
		Parameter	Standard	Test Level /Note
		ESD	BS EN/EN61000-4-2	Level 3, 8KV air ; Level 2, 4KV contact
		Radiated	BS EN/EN IEC1000-4-3	Level 3
		EFT/Burest	BS EN/EN61000-4-4	Level 3
		Surge	BS EN/EN61000-4-5	Level 2, 1KV/Line-Earth ; Level 2, 0.5KV/Line-Line
Conducted		BS EN/EN61000-4-6	Level 3	
Magnetic Field	BS EN/EN61000-4-8	Level 2		
OTHERS	MTBF	4012.9K hrs min.Telcordia SR-332 (Bellcore) ; 303.7K hrs min.MIL-HDBK-217F (25°C)		
	DIMENSION (L*W*H)	101.6*50.8*28.6mm		
	PACKING	0.09kg;96pcs/9.26kg/1.44CUFT		
NOTE	1. 3-phase 48V motor is recommended. Please consider the rated current when used for 12V/24V class motor. 2. Refer to peak current capability in "V/I curve". 3. Efficiency is tested with inductive load at rated current and full power. 4. All parameters NOT specially mentioned are measured at 48VDC input, rated load and 25°C of ambient temperature. 5. Please refer to "Functional Manual" for more details. ※ Product Liability Disclaimer : For detailed information, please refer to https://www.meanwell.com/serviceDisclaimer.aspx			

Block Diagram

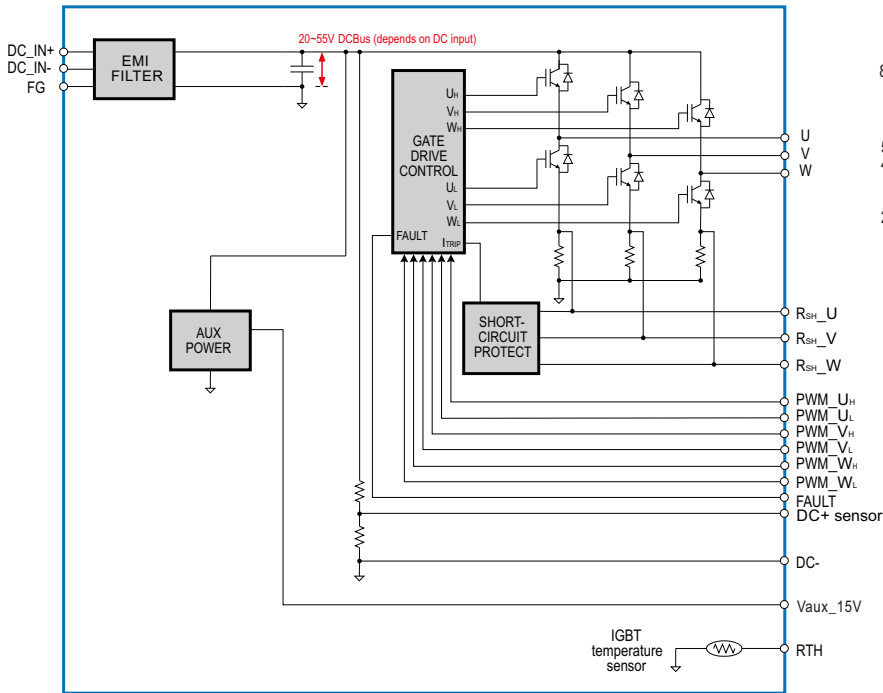

V/I CURVE

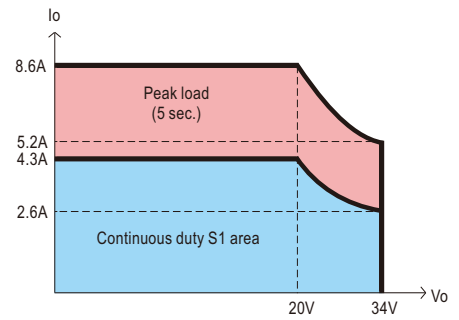

Derating Curve

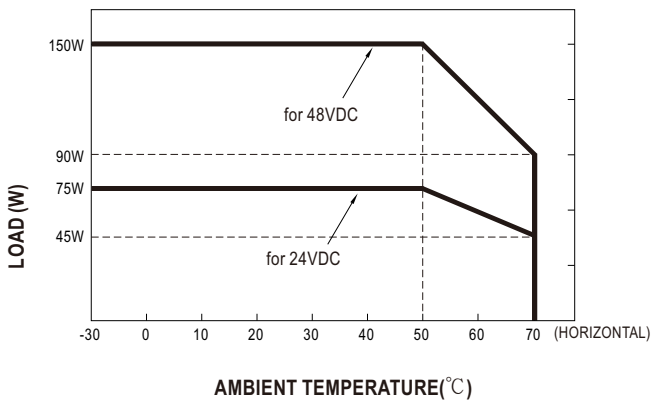

Output Derating VS Input Voltage

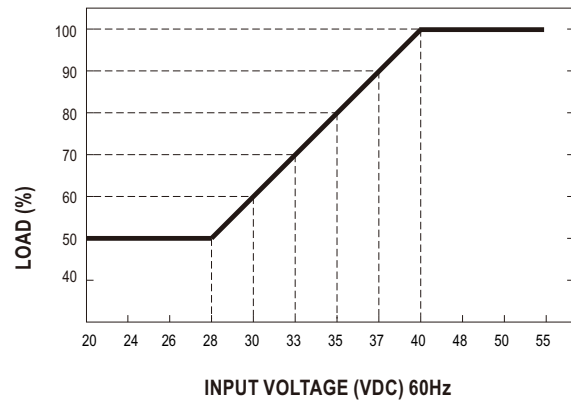

Peak Current

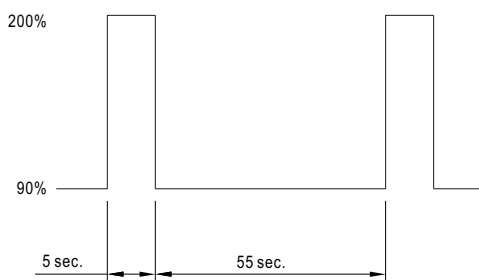

Efficiency vs Load

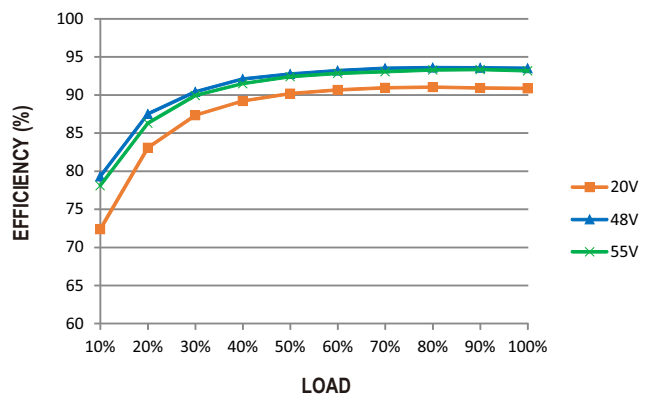

Function Manual

1. 3-phase PWM Control (CN93, PIN8~13)

VFD-150P-48 provides six-switch circuit by using 3 half-bridge IGBTs. IGBTs of each phase is controlled by PWM_U_H/U_L, PWM_V_H/V_L and PWM_W_H/W_L (PIN 8~13). The input requirement for PWM is compatible with both TTL and CMOS 3.3V signals. Please refer to the diagram below.

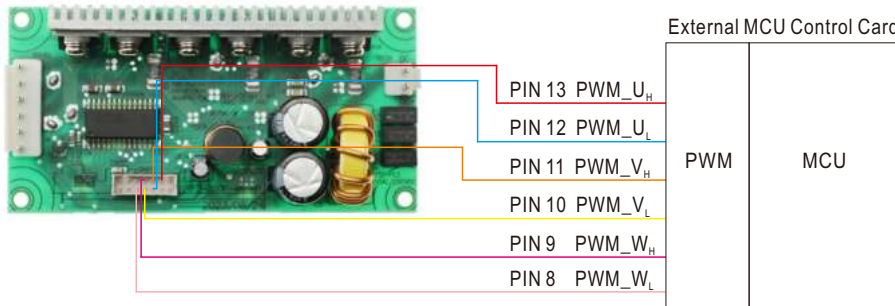

WARNING: It is necessary to keep minimum dead-time 300ns between the upper and lower switch of each phase.

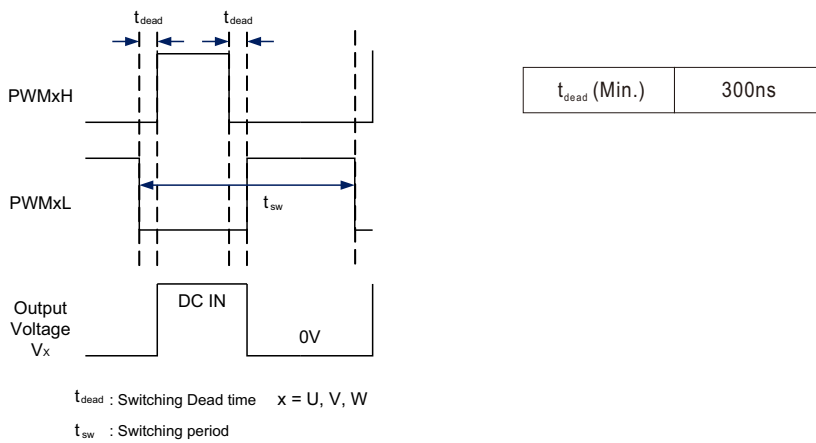

2. 3-phase Current Detection & Overcurrent Protection (CN93, PIN4~6)

Low-side shunt resistors 6mΩ are installed on each phase of VFD-150P-48 for current measurement and short-circuit detection. It's suggested to shorten the length of external detection circuit and detect the signal with a OPAs. Please refer to diagram below.

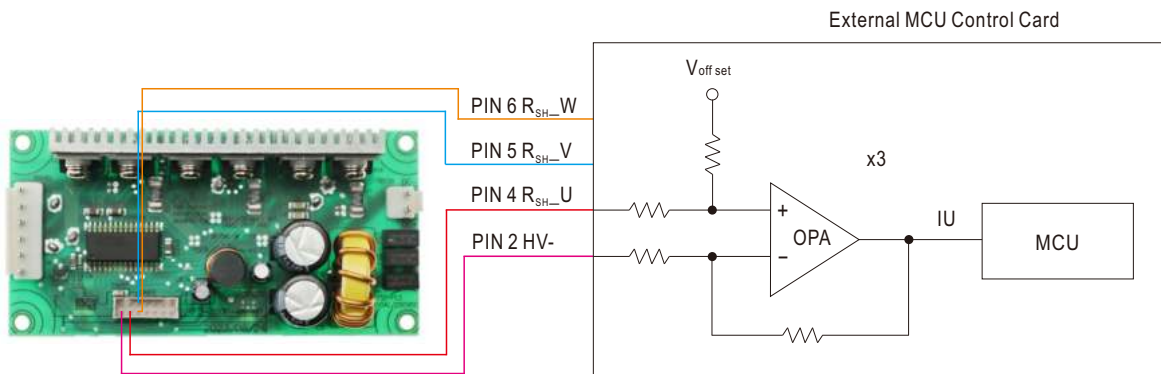

If output current exceeds 200% of rated value, the internal protection circuit will be triggered and shut down the gate driver for protection.

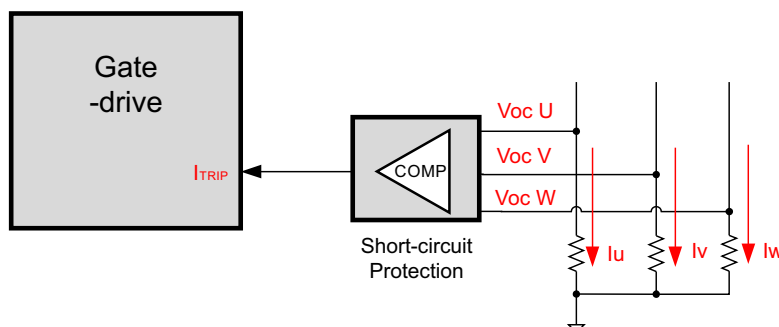

3. DC BUS Voltage Detection (CN93, PIN1)

VFD-150P-48 is build-in with DC bus voltage sensor(DC+ sensor, PIN 1). The sensor provides a 2.5V output when DC bus voltage is at 48V. It's suggested to detect the signal by OPAs. When the voltage of the DC bus exceed 60V, the PWM input signal must shut down for protection.

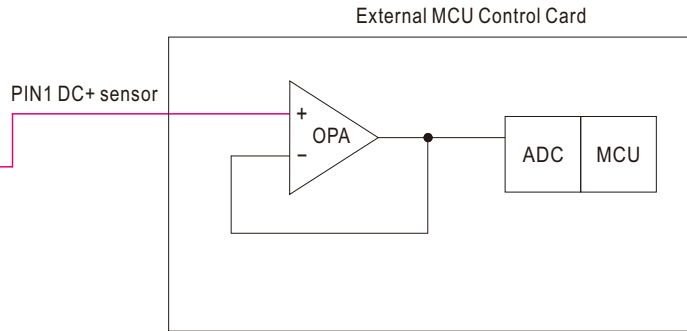
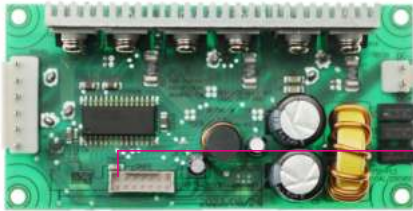

Equation for DC bus voltage calculation:

$$V_{DC\ BUS} = \frac{48 \times DC+sensor}{2.5}$$

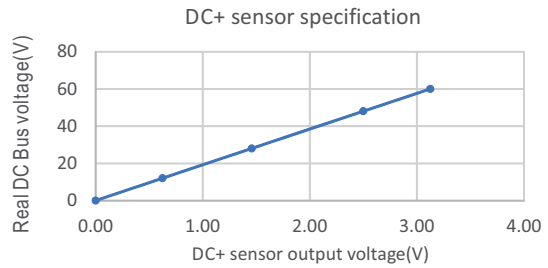

4. IGBT Temperature Detection (CN93, PIN3)

VFD-150P-48 is built-in a NTC resistor for detecting MOS temperature. Users can detect MOS temperature for protection (NTC type: TSM2A103F34D1R, Thinking Electronic). The recommended detection circuit is below. It's suggested to shutdown the PWMs input, if the temperature is above 105°C.

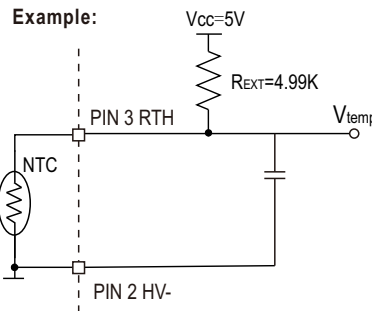
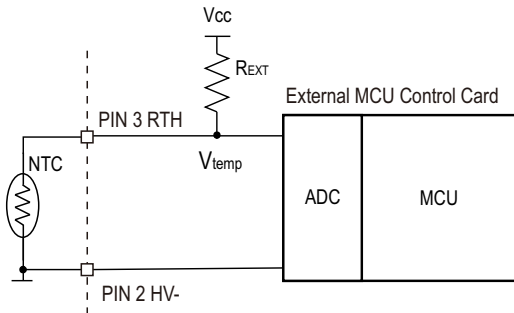

$$V_{temp} = V_{cc} \times \frac{R_{NTC}}{R_{EXT} + R_{NTC}}$$

T _{NTC}	R _{NTC}	V _{temp}
45°C	4.88KΩ	2.47V
105°C	0.86KΩ	0.74V

5. Fault signal

The FAULT signal would be active(active-low) to notify external controller or circuit, if VFD-150P-48 encounter the overcurrent state and keep the state for minimum overcurrent tripping time

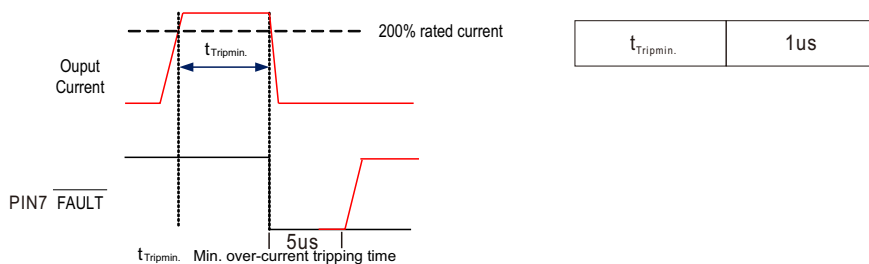

Mechanical Specification

Unit:mm

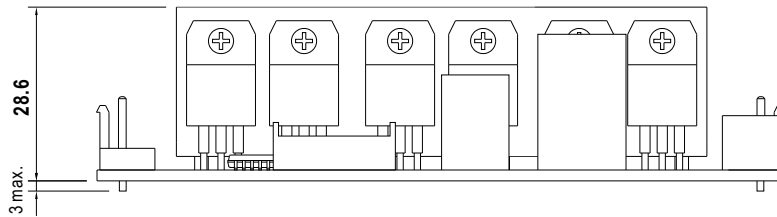
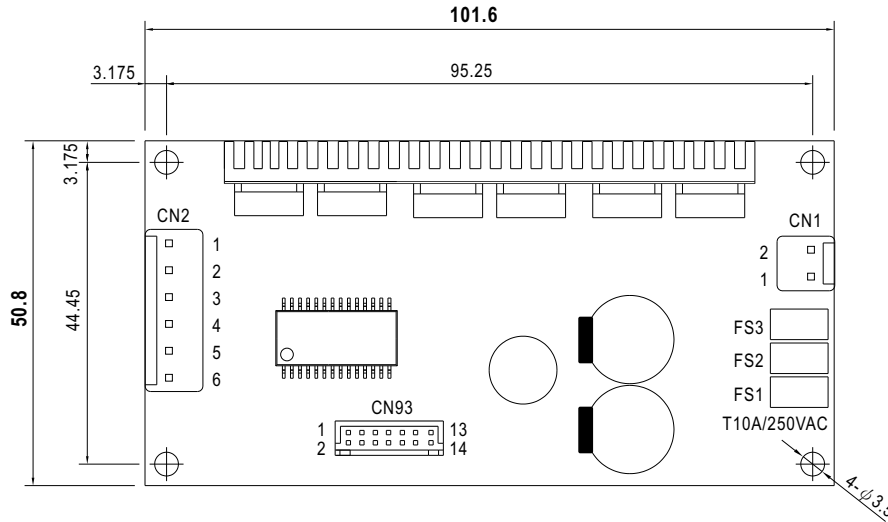

AC Input Connector (CN1) : JST B2P-VH or equivalent

Pin No.	Assignment
1	DC INPUT +
2	DC INPUT -

Mating housing: JST VHR or equivalent
Terminal: JST SVH-21T-P1.1 or equivalent

PWM Output Connector(CN2): JST B6P-VH or equivalent

Pin No.	Assignment
1,2	U
3,4	V
5,6	W

Mating housing: JST VHR or equivalent
Terminal: JST SVH-21T-P1.1 or equivalent

Control Pin NO. Assignment (CN93) : HRS DF11-14DP-2DS or equivalent

Pin No.	Assignment	Pin No.	Assignment
1	DC+ sensor	8	PWM_W _H
2	DC-	9	PWM_W _L
3	RTH	10	PWM_V _H
4	R _{SH-U}	11	PWM_V _L
5	R _{SH-V}	12	PWM_U _H
6	R _{SH-W}	13	PWM_U _L
7	FAULT	14	V _{aux_15V}

Mating housing: HRS DF11-14DS or equivalent
Terminal HRS DF11-**SC or equivalent

※Control Pin No. Assignment(CN93) :

Pin No.	Function	Description
1	DC+ sensor	DC BUS voltage sensor output 2.5V, reference to pin 2(DC-)
2	DC-	DC BUS voltage sensor output ground
3	RTH	Temperature sensor
4	R _{SH-U}	U phase current sensor output
5	R _{SH-V}	V phase current sensor output
6	R _{SH-W}	W phase current sensor output
7	FAULT	Over current detection. Normal > 3V, Abnormal < 0.5V
8	PWM_W _H	W phase high side logic input, on > 2.7V ; off < 0.4V
9	PWM_W _L	W phase low side logic input, on > 2.7V ; off < 0.4V
10	PWM_V _H	V phase high side logic input, on > 2.7V ; off < 0.4V
11	PWM_V _L	V phase low side logic input, on > 2.7V ; off < 0.4V
12	PWM_U _H	U phase high side logic input, on > 2.7V ; off < 0.4V
13	PWM_U _L	U phase low side logic input, on > 2.7V ; off < 0.4V
14	Vaux_15v	Auxiliary voltage output 15V reference to pin2 (DC-). The maximum load current is 0.2A

Application

Application example: BLDC drive application

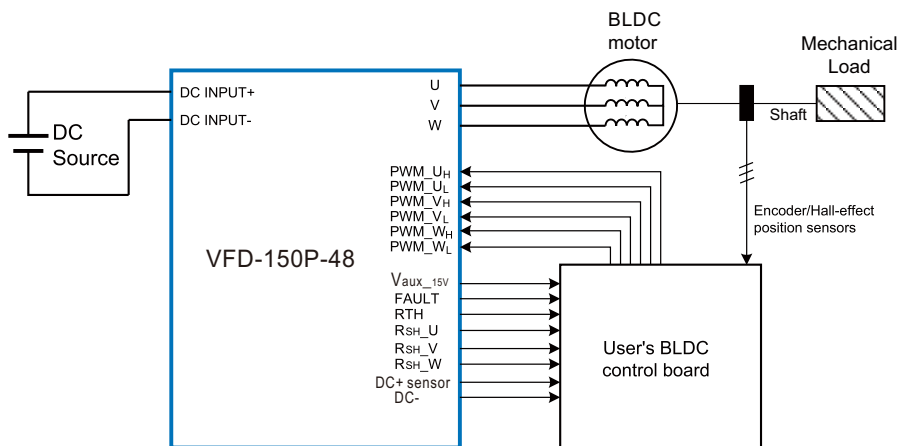

- 1.The figure shows the BLDC drive system which set up with VFD-150P-48.
- 2.Developers can control the PWM signal of 6-switch by using SPWM or SVPWM, etc. for 3-phase voltage modulation, and build the control method base on the current shunt sensors on 3-phase low-side switch(R_{SH-U/V/W}) and the DC BUS voltage sensor(DC+ sensor) which provided by VFD-150P-48.
- 3.Developers select the appropriate BLDC position sensors such as encoder or Hall-effect sensors to fit their applications.
- 4.It's suggested to install the brake circuit/device at the DC input for avoiding the DC BUS OVP when BLDC is decelerating.
- 5.It's suggested to shut down the PWM input or connect to brake resistor device for safety when DC Bus voltage is higher than 60V.
- 6.If VFD-150P-48 were applied non-appropriate control, such as accelerating too quickly or bad current control, it might trig the VFD-150P-48's fault-state to shut down the output voltage(low-level on FAULT pin).

■ Accessory List

If you have any control requirement of specific application, please consult MEAN WELL for more details.
 Motor control board ([Motor control board and VFD drive module should be ordered separately](#)):

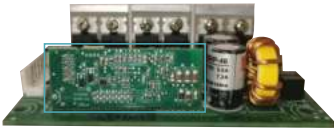
MW's order No.	Control Board	Assembly Suggestion	Quantity
VFD-CB			1

■ Typical Application

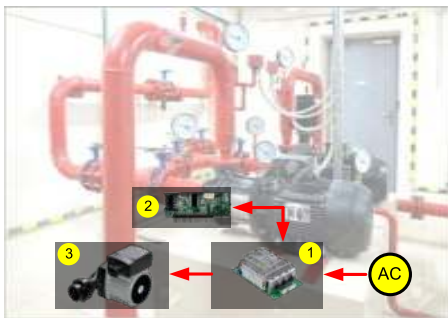

- ① Variable Frequency Module (VFD series)
- ② Control board of Variable Frequency Drive (Designed by User or Solution Provided by MEAN WELL)
- ③ 3-phase Pump Motor

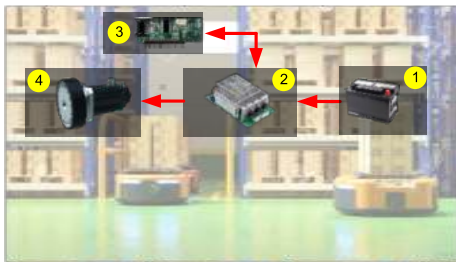

- ① Battery
- ② Variable Frequency Module (VFD series)
- ③ Control board of Variable Frequency Drive (Designed by User or Solution Provided by MEAN WELL)
- ④ 3-phase Wheel Motor for AGV Application

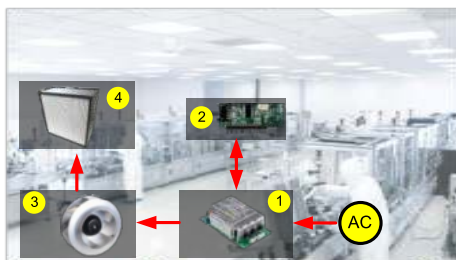

- ① Variable Frequency Module (VFD series)
- ② Control board of Variable Frequency Drive (Designed by User or Solution Provided by MEAN WELL)
- ③ 3-phase Fan Motor
- ④ HEPA for Filtering Air

■ DEMO KIT

Please contact MEAN WELL for more detail.



VFD Demo Kit Main Function and Features.

- ① Built-in VFD-350P-230 and 230V motor.
- ② Motor start /stop/ forward/ reverse/speed control.
- ③ Motor start /stop/forward /reverse indicator right.
- ④ Motor speed (RDM)display.
- ⑤ Control board replaceable.
- ⑥ Support external motor connection.

■ Installation Manual

Please refer to : <http://www.meanwell.com/manual.html>