

Signal Isolator SL332

The SL332 is a field configurable isolating converter providing true 3-way galvanic isolation up to 2500Vrms for standard process signals. Input and output range are set using two 16 position encoder switches that are accessed under a door flap mounted on the front of the module. Key features are;

- Small 12.4mm case size.
- Has a wide range AC/DC power supply.
- 165 factory calibrated input / output ranges.
- Precision digital measurement with digital to analogue conversion after the isolation barrier to remove transfer errors and faster response.
- Two response times.



Order Code

SL332-X X

Supply:

- 1 = 80-300Vdc / 80-280Vac 50/60Hz
- 2 = 10V - 60Vdc / 16 - 42Vac 50/60Hz

Option:

Option Description Conformal Coating

0 = ~~Discontinued~~ Switch Ranges + User Range. N

2 = Switch Ranges + Extended User Settings. N

*) 3 = Switch Ranges + Extended User Settings. Y

About Functionality Options

All SL332 have 165 user selectable input to output range combinations.

Also a user specified range can be set using procedure "User Input / Output Button Calibration" on the next page or by using the SL300 programmer.

Modules with "Extended User Settings" have additional capabilities when programmed with the SL300 programmer.

- Input linearisation.
- User engineering units and scaling.
- Reverse and direct acting
- Signal limiting.
- 20 character name.

General Specifications

Size:	12.4 x 113H x 108D (mm).
Mounting:	Clip for 35mm DIN-Rail.
Housing material:	ABS / Polycarbonate blend
Connection:	Pluggable screw terminals.
Weight:	85g (including packaging).
Protection class:	IP40.
Calibration accuracy:	<0.1%.
Linearity:	<0.1%.
Operating temperature:	-5...+65°C.
Temperature drift:	0.01% per °C.
Load change effect:	< 0.05% (current limited to 22mA)
Response time:	LED on = 400ms LED off = 25ms.
Output drive:	10mA into 0 - 2kΩ, 20mA into 0 - 800Ω.
Input impedance:	1mA/1kΩ, 10mA/100Ω, 100mA/36Ω (Term 6). Voltage input / > 1MΩ (Term 7).
Loop power output:	19V / 24mA (Used to power input devices. Term 5)
Overload continuous:	Voltage input: 900V MAX. Current input: 100mA MAX.
Noise immunity:	130dB CMRR.
Input/output isolation:	>2.5kVrms.
EMC:	AS/NZS 4251.1 (EN 50081.1)

Input (IP) and Output (OP) Switch Selection

IP	Input	OP	Output
0	Button Cal	0	Button Cal
1	0-1mA	1	0-1mA
2	0-10mA	2	0-10mA
3	0-20mA	3	0-20mA
4	4-20mA	4	4-20mA
5	0-50mA	5	0-1V
6	0-1V	6	0-2V
7	0-2V	7	0-5V
8	0-5V	8	1-5V
9	1-5V	9	0-10V
A	0-10V	A	2-10V
B	2-10V	B	0-20V
C	0-20V	C	
D	0-50V	D	
E	0-100V	E	
F	200V		
F	User range	+ F	User range

Select Pre-Calibrated Range

1. Set switch **IP** to desired input.
2. Set switch **OP** to desired output
3. Input and output are now calibrated.
4. Connect to the correct input terminals for your input signal choice (refer to connections on the next page).

*) = Price Extra.

In the interest of development and improvement, APCS reserve the right to amend, without notice, details contained in this publication. APCS will accept no legal liability for any errors, omissions or amendments.

User Input / Output Button Calibration

This procedure requires test equipment and practical experience in calibration to get the correct result. It only affects the user range when both switches are set on F. All other ranges will retain factory calibration.

The SL300 programmer may be used to calibrate the user range (without test equipment) instead of the following.

1. Set switches **IP** and **OP** to position 0.
2. Hold down programming button until the slow response LED1 starts to flash and then release.
3. Set switches **IP** and **OP** according to input and output signal requirements.
e.g. Input = 7 to 9mA and Output = 0.3 to 0.9V output, set **IP** to 2 and **OP** to 5.
4. Press the programming button. The slow response LED should flash once to indicate that input and output ranges are remembered.
5. Apply input zero (7mA in this example) and measure output with an external meter.
6. Adjust **OP** switch for zero scale output (0.3V in this example). Use **IP** to switch to set the sensitivity of the **OP** switch, F=course and 0=fine.
7. Press the programming button. The slow response LED should flash twice to indicate that input and output zero scale is remembered.
8. Apply input full scale signal (9mA in this example). Adjust **OP** switch for full scale output (0.9V in this example). Use **IP** to switch to set the sensitivity of the **OP** switch, F=course and 0=fine.
9. Press the programming button. The slow response LED should flash three times to indicate that input and output full scale is remembered.
10. Set switches **IP** and **OP** SW2 to position F and check input output calibration.

If caught half way through a button programming sequence reset the power and start again.

Connection and under door controls

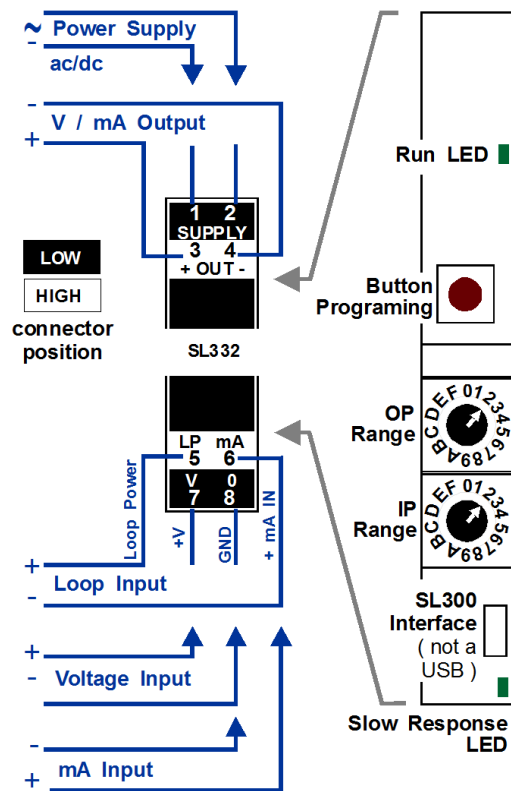

Change Response Time

Use SL300 programmer or follow this procedure using the switches and buttons.

1. Set switch **IP** to position 0.
2. Set switch **OP** to position 0
3. Hold down, do not release the programming Button.
4. The slow response LED will flash 16 to 20 times before stopping in the new response time state.
5. Release the programming Button.
6. Set switches **IP** and **OP** to the required positions.