

Dual Trip Alarm v5 DTA137

DESCRIPTION

The DTA137 is suitable for all standard process signals and all common types of sensors, featuring two independently adjustable trip points with true relay contact outputs. The standard Dual Trip Alarm will accept DC voltage or current input signals directly (0.1V up to 2kV, 0.1mA up to 2A). Low level sensor or AC input signals require an optional input conditioning card, which is factory fitted. Special requirements for input response time variation can be accommodated using the customised response option. Other options such as extreme low input load (25Ω at 20mA) can also be manufactured. The trip circuits are operated directly from the pre-conditioned input circuit. Trip status is indicated by red LED's. The action of trip operation, e.g. high or low alarm is internally selectable by coding plugs. Both relay contact outputs can also be configured internally to be normally open or normally closed. Dead band is adjustable from 0.5 to 30% via the front accessible trim pots. Various power supply choices are available ranging from 240Vac down to 8Vdc. All supply models contain a dual output for power isolation. Surge protection for power supply and input is standard with all APCS modules.



General Specifications

Size:	52 W x 70 H x 110 D (mm).
Housing material:	ABS.
Mounting:	DIN-Rail, gear plate.
Termination:	Screw terminals on front Terminal covers standard.
Weight:	0.300 kg.
Protection class:	IP40.
Operating temperature range:	-10...+60°C.
Storage temperature range:	-20...+70°C.
Repeatability:	0.1% of range.
Temperature drift of trip-point:	0.01% / °C.
Relay contact:	Change-over and N/O or N/C 8A/250V resistive 3.5A/250V inductive.
Contact isolation:	2kV.
Auxiliary DC supply:	24Vdc, 25mA max.
Dead band:	0.5% to 30%
Power requirements:	3W.
Electromagnetic compatibility:	AS/NZS 4251.1 (EN 50081.1)

Block Diagram

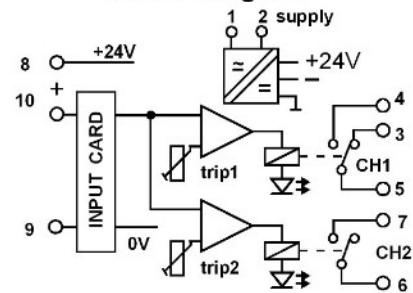

Connections

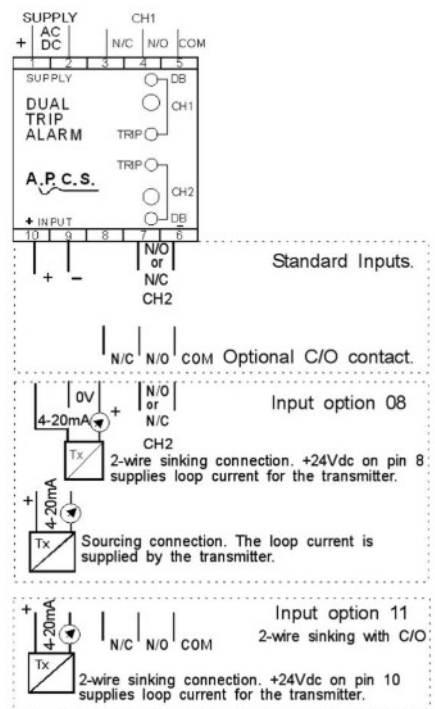

For input / output combinations refer to TYPE NO. DESIGNATION overleaf.

TYPE NO. DESIGNATION

Power Supply:

- 0 = Signal powered (see inputs).
- 1 = 90-280Vac 50/60Hz (65-280Vdc).
- *) 3 = 16-48Vac 50/60Hz (10-60Vdc)
- *) 4 = 8 - 60Vdc.
- 9 = Other (Specify).

Input:

- 01 = 0 – 0.1V (100kΩ).
- 02 = 0 – 1V (100kΩ).
- 03 = 0 – 2V (100kΩ).
- 04 = 0 – 5V (200kΩ).
- 05 = 0 – 10V (500kΩ).
- 06 = 0 – 1mA (1kΩ).
- 07 = 0 – 10mA (100Ω).
- # 08 = 0 - 20mA, 4 – 20mA (100Ω).
- *) 09 = Other (Specify).
- *) 10 = Optional input, see options below.
- 11 = 4 - 20mA. (2-wire +24V on pin10)
- 12 = 0 – 20mA, 4 – 20mA (externally sourced)
- 20 = 80 – 160Vac signal power.
- 21 = 180 - 260Vac signal power
- *) 22 = 8 – 60Vdc signal power.
- *) 23 = 60 – 160Vdc signal power.
- *) 29 = Other signal power, specify.
- *) 30 = Continuity constant 2mA limit 7V5 SPL0990

Trip Action and Contact Configuration:

- 1 = CH1 DIR C/O, CH2 DIR N/O
 - 2 = CH1 DIR C/O, CH2 DIR N/C
 - 3 = CH1 REV C/O, CH2 REV N/O
 - 4 = CH1 REV C/O, CH2 REV N/C
 - 5 = CH1 DIR C/O, CH2 REV N/O
 - ▲ 6 = CH1 DIR C/O, CH2 DIR C/O
 - ▲ 7 = CH1 REV C/O, CH2 REV C/O
 - ▲ 8 = CH1 DIR C/O, CH2 REV C/O
 - A = CH1 DIR N/O, CH2 DIR N/O.
 - B = CH1 DIR N/O, CH2 DIR N/C.
 - C = CH1 REV N/C, CH2 REV N/O.
 - D = CH1 REV N/C, CH2 REV N/C.
 - G = SPL0686A Latching + RESETS
(see drawing PL68610)
 - *) 9 = Other (Specify).
- DIR = Direct acting relay energised with input above set-point
 REV = Reverse acting relay energised with input below set-point
 N/O = Normally open contact, open when relay de-energised.
 N/C = Normally closed contact, closed when relay de-energised.
 C/O = Change-over contact.

Options:

- 00 = None.
- *) 01 = Thermocouple input.
- *) 02 = RTD input.
- *) 03 = Frequency input. Calibration range 0 - 10Hz...0 - 5kHz (Sine, Triangle)
Sensitivity: 200mVpp. (70mV rms) min. 22Vpp. max (Square, Pulse).
- *) 04 = Pulse input from NAMUR proximity sensor or passive device (contact, open collector). Auxiliary supply of 8Vdc at terminal 8, other data as option 03 above.
- *) 05 = AC input (current via external shunt).
- *) 06 = Bipolar / millivolt input. (±0.5mV to ±2kV bipolar) (1mV to 2kV unipolar).
- *) 07 = Resistance input (constant current).
- *) 08 = Customised response time.
- *) 09 = pH/Electrochemical sensor input
- *) 10 = Adder or Subtractor. 2 inputs 4 - 20mA floating.
- *) 12 = True rms (any wave form).
- *) 13 = AC current (internal CT).
- *) 14 = Conductivity. (50µS/cm to 100mS/cm [k=1]).
- *) 15 = Dissolved oxygen input.
- *) 16 = Vibration piezo transducer.
- *) 17 = Load cell input (use with trip actions A to D).
- *) 18 = pH/ORP with Pt100 Temp Comp.
- *) 33 = Use with APCS external current transformer, specify one SCT007(50A), SCT012(100A), SCT008(200A), SCT009(600A) and scaling. External APCS CT's are ordered separately.
- *) 42 = Potentiometer 3W voltage excited.
- *) 99 = Other (Specify).

Definitions

- # = Includes 24Vdc/25mA on terminal 8 on all contact configurations except 6, 7 & 8.
- ▲ = Change over contact outputs are only available for 2-wire inputs.
- = Cannot order a ■ with a ▲.

*) Price Extra

In the interest of development and improvement, APCS reserve the right to amend, without notice, details contained in this publication. APCS will accept no legal liability for any errors, omissions or amendments.