

esi

HIPRES® HP1000H

Hydrogen High Pressure Transmitter

- Compatible for use within hydrogen based environments
- Silicon-on-Sapphire sensor technology for outstanding performance
- Pressure ranges to 1,000 bar to 5,000 bar
- Pressure diaphragm and process connection is machined from one piece of Titanium with no seals or welds
- High resistance to overpressure and pressure transients
- ATEX/IECEx option available (includes M1 for mining applications) for 4-20 mA versions
- DNV-GL certification available



Materials used in the manufacture of the Hydrogen range have been tested based on ISO 11114-2:2017 in accordance to the European Regulations EC 79/2009 and EU 406/2010 to determine an "embrittlement index" of the material when placed in a saturated environment over an extended period of time.

Results have provided a Pass rating to the compatibility of the specialist Titanium Alloy of the range against Hydrogen.

Specifications

The **HIPRES HP1000H** series of Hydrogen compatible high pressure transmitters with state-of-the-art SOS sensor technology offers high performance pressure measurement in extremely high pressure applications up to 5,000 bar ranges. ATEX and IECEx approval and protection by intrinsic safety is optional and intended for installation and operation in zone 0, gas group IIC, temperature class T4 and zone 20 dust and M1 mining. DNV GL rules for classification of ships, high speed & light craft and DNV GL offshore standards.

Typical applications include:

- Hydrogen storage
- Pipeline testing
- High pressure Industrial



Dimensions (in mm)

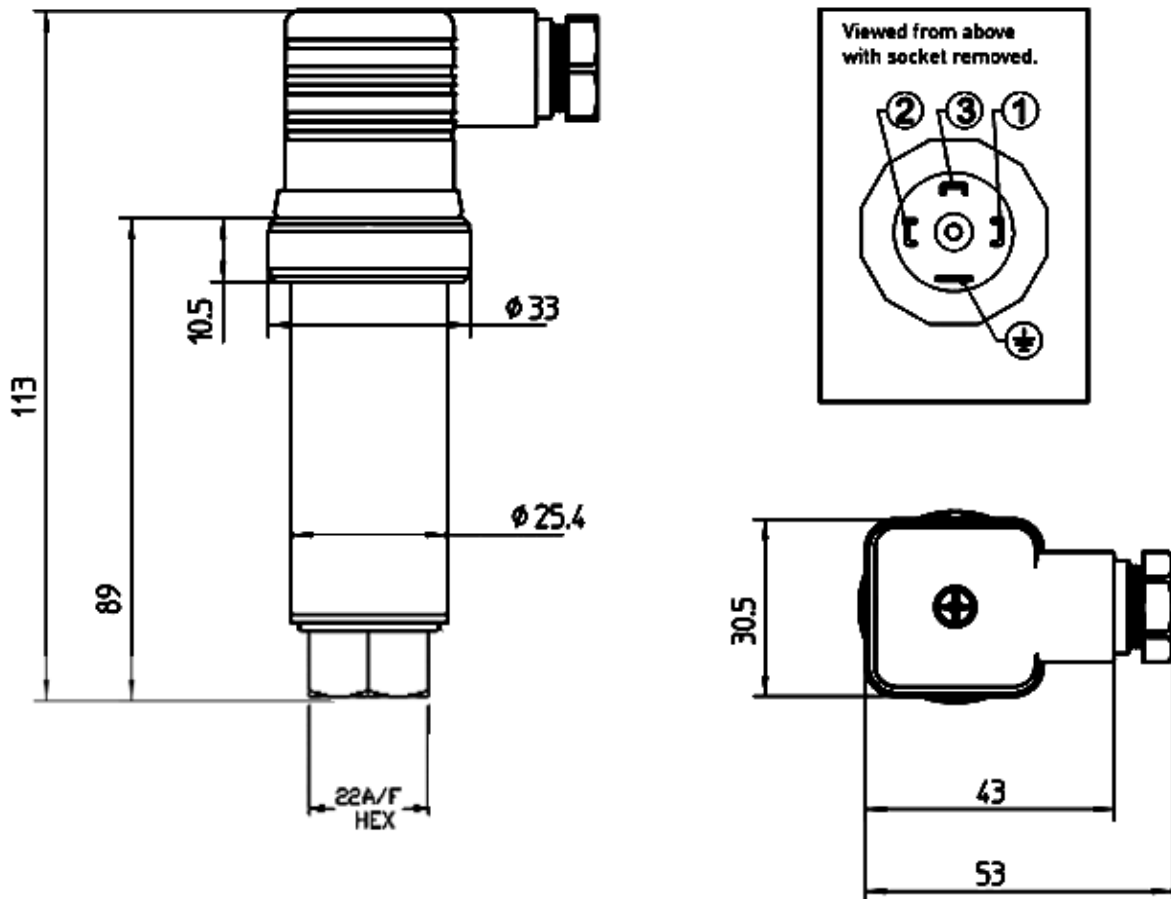

Electrical Connections

Pin No.	mA		VDC	
	2 wire	3 wire	4 wire	
1	+supply	common	-supply	
2	4-20mA	+supply	+supply	
3	N/C	+output	+output	
⊥	to case	to case	-output	

Hydrogen Compatibility and Silicon-on-Sapphire

The ESI hydrogen pressure transmitters are manufactured from a special titanium alloy for the measuring cell and a titanium block for the wetted parts. High pressure cells ranging from 1,000 bar are manufactured without seams, which aids in the avoidance of any weak points. This is especially important for the use with hydrogen due to the embrittling qualities of the media.

The combination of titanium sensing elements with SOS sensors has a long tradition at ESI, this material choice allows the construction of a long term stable sensor that has a high accuracy. The measurement ranges for this product are up to 1,500 bar, which makes this transmitter the preferred choice for use on hydrogen storage tanks and pipelines, but we also offer the same technology for low pressures and also in vacuum measurement applications.



The unique Silicon-on-Sapphire sensor technology provides outstanding performance and gives excellent stability over a wide temperature range. The advanced sensor design consists of a piezoresistive silicon strain gauge circuit, which is epitaxially grown onto the surface of a sapphire diaphragm to form a single crystalline structure. The sapphire sensor element is then molecularly bonded to a titanium alloy sub-diaphragm. This enables the sensor to endure higher over-pressures and provides superb corrosion resistance. The sensor exhibits virtually no hysteresis and excellent long-term stability. With outstanding insulation properties, the sapphire substrate allows the sensor to operate over a very wide temperature range without loss of performance.

Each Hydrogen approved unit also includes a certificate of conformity verifying Hydrogen compatibility.

Optional Approvals



Hazardous Area: ATEX and IECEx approval for explosion protection; flammable gases (zone 0), dusts (zone 20) and mining areas (group I M1).



Marine: DNV-GL marine approvals for marine use has been developed for shipping systems such as marine engines, cargo storage tanks, fuel gauging, fresh water storage, wastewater management, heating, cooling and ballast tank control.



Technical Data

Type	HP1000/HP1100	HP1xx1	HP1xx2	HP1003/HP1103
Sensor Technology:	Silicon-on-Sapphire (SOS)			
Output Signal:	0-10 mV/V (4 wire)	0-5 V (4 or 3 wire)	0-10 V (4 or 3 wire)	4-20 mA (2 wire)
Supply Voltage:	10 VDC (5-15 V)	13-30 VDC	13-30 VDC	10-36 VDC
Pressure Reference:	Gauge			
Protection of Supply Voltage:	Protected against supply voltage reversal up to 50 V (amplified versions)			
Standard Pressure Ranges (bar):	HP10xx: 0-1,000 bar; 0-1,500 bar; 0-2,000 bar HP11xx: 0 – 2,500 bar; 0 – 4,000 bar; 0 – 5,000 bar (other ranges available)			
Standard Pressure Ranges (psi):	0-10,000 psi; 0-15,000 psi; 0-20,000 psi; 0-30,000 psi; 0-40,000 psi; 0-60,000 psi; 0-72,000 psi (other ranges available)			
Overpressure Safety:	1.5x for ranges 0 – 1000 bar to 0 – 3,000 bar; 1.25x for 4,000 bar; 1.2x for 5,000 bar			
Load Driving Capacity:	4 – 20 mA: $RL < [UB - 10 V] / 20 \text{ mA}$ (e.g. with supply voltage (UB) of 36 V, max. load (RL) is 1300 Ω) 10 mV/V: n/a; 0 – 5 V: max. load RL > 5 KΩ; 0 – 10 V: max. load RL > 10 KΩ			
Accuracy NLHR:	≤ ±0.25 % of span BSL (ranges above 3,000 bar: ≤ ±0.25 % of span BSL) (optional higher accuracy version of ≤ ±0.1 % of span BSL available)			
Zero Offset and Span Tolerance:	±0.5 %FS at room temperature (GS4201: ±1 mV); ±5 %FS (approx.) adjustment with easy access trimming potentiometers on amplified versions only			
Operating Temperatures:	Ambient: -40 °C to +85 °C (-40 °F to +185 °F) Media: -50 °C to +125 °C (-58 °F to +257 °F)			
Storage Temperature:	+5 °C to +40 °C (+41 °F to +104°F) Recommended Best Practice			
Temperature Effects:	±1.5 %FS total error band for -20 °C to +70 °C. Typical thermal zero and span coefficients ±0.015 %FS /°C			
ATEX/IECEX Approval Option (4-20 mA version only):	n/a	n/a	n/a	Ex II 1 G Ex ia IIC T4 Ga (zone 0) Ex II 1 D Ex ia IIIC T135 °C Da (zone 20) Ex I M 1 Ex ia I Ma (group 1 M1)
ATEX/IECEX Safety Values:	n/a	n/a	n/a	Ui = 28 V Ii = 119 mA Pi = 0.65 W Li = 0.1 μH Ci = 74 nF Temperature Range = -20 °C to +70 °C Max. cable length = 45 m
DNV-GL Approval:	Temperature: D; Humidity: B; Vibration: B; EMC: B; Enclosure: C (contact sales for more information)			
Electromagnetic Compatibility:	Emissions: EN61000-6-3; Immunity: EN61000-6-2; Certification: CE Marked			
Insulation Resistance:	> 100 MΩ @ 50 VDC			
Response Time 10-90%:	1 mS			
Wetted Parts:	Titanium alloy machined from a single piece (other options available)			
Pressure Media:	Hydrogen and all fluids compatible with Titanium alloy (other options available)			
Pressure Connection:	F250-C Autoclave fitting; thread type 9/16-18UNF-2B female or M16 x 1.5 female cone seal			
Electrical Connection:	Mating socket EN175301-803 Form A (ex DIN43650) rated IP65 with PG9 cable entry (other options available)			
Net Weight:	0.2 Kg			

Order Matrix

Output		Wires	Type	Options	Pressure Range	Process Connection			
10 mV/V	Model to 2,000 bar (incl. 30,000 psi)	4	HP1000						
	Model above 2,000 bar	4	HP1100						
0-5 V	Model to 2,000 bar (incl. 30,000 psi)	4	HP1001						
	Model above 2,000 bar	4	HP1101						
	Model to 2,000 bar (incl. 30,000 psi)	3	HP1011						
	Model above 2,000 bar	3	HP1111						
0-10 V	Model to 2,000 bar (incl. 30,000 psi)	4	HP1002						
	Model above 2,000 bar	4	HP1102						
	Model to 2,000 bar (incl. 30,000 psi)	3	HP1012						
	Model above 2,000 bar	3	HP1112						
4-20 mA	Model to 2,000 bar (incl. 30,000 psi)	2	HP1003						
	Model above 2,000 bar	2	HP1103						
Options									
DIN EN175301 plug and socket							-		
Cable outlet 1m screened				HA					
M12 connector				HB					
Cable outlet 1m screened IP67 protection				HC					
ATEX/IECEX certified with DIN EN175301 plus and socket				EXH					
DNV GL approval				MH					
DNV GL approval plus ATEX/IECEX certified				EXG					
Pressure Range					0600				
0-1000 bar					1000				
0-1500 bar					1500				
0-2000 bar					2000				
0-3000 bar					3000				
0-4000 bar					4000				
0-5000 bar					5000				
Process Connection									
Autoclave F-250-C female						DE			
M16 x 1.5 female cone seal						FK			

Order Number Example

HP1000H1000DE

For options not listed please contact the sales team

DISCLAIMER : ESI Technology Ltd operates a policy of continuous product development. We reserve the right to change specification without prior notice. All products manufactured by ESI Technology Ltd are calibrated using precision calibration equipment, traceable to national measurement standards.