

SD Card real time data recorder
%RH, Light, Anemometer, Temp, all in one

ENVIRONMENT METER

Model : EMC-9400SD



Your purchase of this ENVIRONMENT METER marks a step forward for you into the field of precision measurement. Although this Meter is a complex and delicate instrument, its durable structure developed. Please read the following instructions carefully and always keep this manual within easy reach.

OPERATION MANUAL

TABLE OF CONTENTS

1. FEATURES.....	1
2. SPECIFICATIONS.....	2
3. FRONT PANEL DESCRIPTION.....	7
4. MEASURING PROCEDURE.....	9
4-1 Function selection	9
4-2 Anemometer/Temp. measurement.....	10
4-3 Humidity/Temp. measurement.....	11
4-4 Type K/J Temperature measurement.....	11
4-5 Light measurement.....	12
4-6 Data Hold.....	13
4-7 Data Record (Max./ Min. reading).....	13
4-8 LCD brightness select.....	14
5. DATALOGGER.....	15
5-1 Preparation before execute datalogger function.....	15
5-2 Auto Datalogger(Set sampling time \geq 1 second).....	16
5-3 Manual Datalogger (Set sampling time = 0 second).....	17
5-4 Check time & sampling time information.....	17
5-5 SD Card Data structure.....	18
6. Saving data from the SD card to the computer.....	19
7. ADVANCED SETTING.....	20
7-1 Set clock time (Year/Month/Date, Hour/Minute/ Second).....	21
7-2 Auto power OFF management.....	21
7-3 Set beeper sound ON/OFF	22
7-4 Set sampling time (Second).....	22
7-5 Set SD card Decimal character.....	22
7-6 Select the temperature Type K/J	23
7-7 Set area dimension	23
7-8 SD memory card Format.....	24
7-9 Select the Air Flow to CMM or CFM.....	24
8. POWER SUPPLY from DC ADAPTER.....	25
9. BATTERY REPLACEMENT.....	25
10. SYSTEM RESET.....	25
11. RS232 PC serial interface.....	26
12. Optional Type K Temp. probe.....	27
13. PATENT.....	28

1. FEATURES

- * Environment instrument, multi-function, all in one.
- * Type K/J thermometer, Humidity/Temp. meter, Anemometer, Light meter.
- * Humidity measurement can show %RH and Temp., Dew , Wet Temp.
- * Anemometer can default the display unit to m/S, FPM, Km/h, mph, knot. And CMM , CFM
- * Light meter can default the display unit to LUX or Ft-cd.
- * Thermocouple Thermometer can default to accept type K or type J Temp. probe.
- * Temp. display unit default to °C or °F.
- * Meter can default auto power off or manual power off.
- * Real time SD memory card Datalogger, it Built-in Clock and Calendar, real time data recorder , sampling time set from 1 second to 3600 seconds.
- * Manual datalogger is available (set the sampling time to 0), during execute the manual datalogger function, it can set the different position (location) No. (position 1 to position 99).
- * Innovation and easy operation, computer is not need to setup extra software, after execute datalogger, just take away the SD card from the meter and plug in the SD card into the computer, it can down load the all the measured value with the time information (year/month/date/ hour/minute/second) to the Excel directly, then user can make the further data or graphic analysis by themselves.
- * SD card capacity : 1 GB to 16 GB.
- * LCD with green light backlight, easy reading.
- * Can default auto power off or manual power off.
- * Data hold, record max. and min. reading.
- * Power by UM3/AA (1.5 V) x 6 batteries or DC 9V adapter.
- * RS232/USB PC COMPUTER interface.
- * Available for the HVAC applications.

2. SPECIFICATIONS

2-1 General Specifications

Circuit	Custom one-chip of microprocessor LSI circuit.	
Display	TFT LCD size : 2.4 "	
Measurement function	<ul style="list-style-type: none"> * Anemometer with Temp.,CMM,CFM * Humidity/Temp. meter,DEW ,WET * Light meter * Type K/J thermometer 	
Datalogger Sampling Time Setting range	Auto	1 second to 3600 seconds @ For anemometer measurement, the sampling time setting value should be ≥ 2 seconds. @ Sampling time can set to 1 second, but memory data may loss.
	Manual	Push the data logger button once will save data one time. @ Set the sampling time to 0 second. @ Manual mode, can also select the 1 to 99 position (Location) no.
Memory Card	SD memory card. 1 GB to 16 GB.	
Advanced setting	<ul style="list-style-type: none"> * Set clock time (Year/Month/Date, Hour/Minute/ Second) * Auto power OFF management * Set beep Sound ON/OFF * Set sampling time * Decimal point of SD card setting * Set thermometer type to Type K or Type J * Set area dimension * SD memory card Format * Select the Air Flow to CMM or CFM 	

Temperature Compensation	Automatic temp. compensation for the Anemometer function and the type K/J thermometer.	
Data Hold	Freeze the display reading.	
Memory Recall	Maximum & Minimum value.	
Sampling Time of Display	Approx. 1 second.	
Data Output	RS 232/USB PC computer interface. * Connect the optional RS232 cable UPCB-02 will get the RS232 plug. * Connect the optional USB cable USB-01 will get the USB plug.	
Operating Temperature	0 to 50 °C.	
Operating Humidity	Less than 85% R.H.	
Power Supply	* Alkaline or heavy duty DC 1.5 V battery (UM3, AA) x 6 PCs, or equivalent.	
	* DC 9V adapter input. (AC/DC power adapter is optional).	
Power Current	Normal operation (w/o SD card save data) : <i>Approx. DC 58mA.</i>	
	When SD card save the data <i>Approx. DC 70 mA.</i>	
Weight	515 g/ 1.13 LB.	
Dimension	Meter	135 x 60 x 33 mm.
	Probe	105 x 46 x 29 mm.
Accessories Included	* Instruction manual..... 1 PC * Anemometer Probe, AM-01..... 1 PC * Humidity Probe, HT-01..... 1 PC * Light Probe, LX-01..... 1 PC * Type K thermocouple Probe, TP-01..... 1 PC * Hard carrying case (CA-08)..... 1 PC	

Optional Accessories	<ul style="list-style-type: none"> * SD Card (4 G) * Type K thermocouple probe. TP-02A. TP-03, TP-04 * AC to DC 9V adapter. * USB cable, USB-01. * RS232 cable, UPCB-02. * Data Acquisition software, SW-U801-WIN.
----------------------	--

2-2 Electrical Specifications (23±5 °C)

Anemometer

A. Air velocity

Measurement	Range	Resolution	Accuracy
m/S	0.4 - 25.0 m/s	0.1 m/s	±(2% + 0.2 m/s)
km/h	1.4 - 90.0 km/h	0.1 km/h	±(2% + 0.8 km/h)
mph	0.9 - 55.9 mile/h	0.1 mile/h	±(2% + 0.4 mile/h)
knot	0.8 - 48.6 knots	0.1 knots	±(2% + 0.4 knots)
FPM	80 - 4930 ft/min	1 ft/min	±(2%+40 ft/min.)
<i>Note:</i>	m/S - meters per second	km/h - kilometers per hour	
	FPM - feet/per minute	knot - nautical miles per hour	
	mph - miles per hour	(international knot)	

B. Temperature

<i>Measuring Range</i>	0 °C to 50 °C/32 °F to 122 °F
<i>Resolution</i>	0.1 °C/0.1 °F
<i>Accuracy</i>	±0.8 °C/1.5 °F

Air flow

Measurement	Range	Resolution
CMM (m ³ /min.)	0 to 45,000 CMM	0.001 to 1 CMM
CFM (ft ³ /min.)	0 to 1,589,200 CFM	0.001 to 100 CFM

Measurement	Area
CMM (m ³ /min.)	0.001 to 30.000 m ²
CFM (ft ³ /min.)	0.01 to 322.93 ft ²

Humidity/Temp. meter

A. Humidity

Measuring Range	0 % to 95 % R.H.
Resolution	0.1 % R.H.
Accuracy	$\geq 70\% \text{ RH} : \pm(3\% \text{ reading} + 1\% \text{ RH}).$ $< 70\% \text{ RH} : \pm 3\% \text{ RH}.$

B. Temperature

Measuring Range	0 °C to 50 °C/32 °F to 122 °F
Resolution	0.1 °C/0.1 °F
Accuracy	$\pm 0.8 \text{ °C}/1.5 \text{ °F}$

Dew Point (Humidity)

°C	Range	-25.3 °C to 48.9 °C
	Resolution	0.1 °C
°F	Range	-13.5 °F to 120.1 °F.
	Resolution	0.1 °F.
Remark : * Dew Point display value is calculated from the Humidity/Temp. measurement automatically. * The Dew Point accuracy is sum accuracy value of Humidity & Temperature measurement..		

Wet bulb (Humidity)

°C	Range	-21.6 °C to 50.0 °C
	Resolution	0.1 °C
°F	Range	-6.9 °F to 122.0 °F.
	Resolution	0.1 °F.

Remark :

- * Wet bulb display value is calculated from the Humidity/Temp. measurement automatically.
- * The Welt bulb accuracy is sum accuracy value of Humidity & Temperature measurement..

Light meter

Measuring Range	LUX	0 to 20,000 LUX.
	Ft-cd	0 to 1,860 Ft-cd
Resolution	LUX	1 LUX
	Ft-cd	0.1 Ft-cd
Accuracy	± (5% rdg ± 8 dgt)	

Note:

Ft-cd : Feet candle

Type K/J Thermometer

Sensor Type	Resolution	Range	Accuracy
Type K	0.1 °C	-50.0 to 1300.0 °C	± (0.4 % + 0.8 °C)
		-50.1 to -100.0 °C	± (0.4 % + 1 °C)
	0.1 °F	-58.0 to 2372.0 °F	± (0.4 % + 1.5 °F)
		-58.1 to -148.0 °F	± (0.4 % + 1.8 °F)
Type J	0.1 °C	-50.0 to 1200.0 °C	± (0.4 % + 0.8 °C)
		-50.1 to -100.0 °C	± (0.4 % + 1 °C)
	0.1 °F	-58.0 to 2192.0 °F	± (0.4 % + 1.5 °F)
		-58.1 to -148.0 °F	± (0.4 % + 1.8 °F)

* Accuracy value is specified for the meter only.

* Temp. probe (Type K, TP-01 TP-02A, TP-03. TP-04) is the optional accessories, refer page 27.

* Above specification tests under the environment RF Field Strength less than 3 V/M & frequency less than 30 MHz only.

3. FRONT PANEL DESCRIPTION

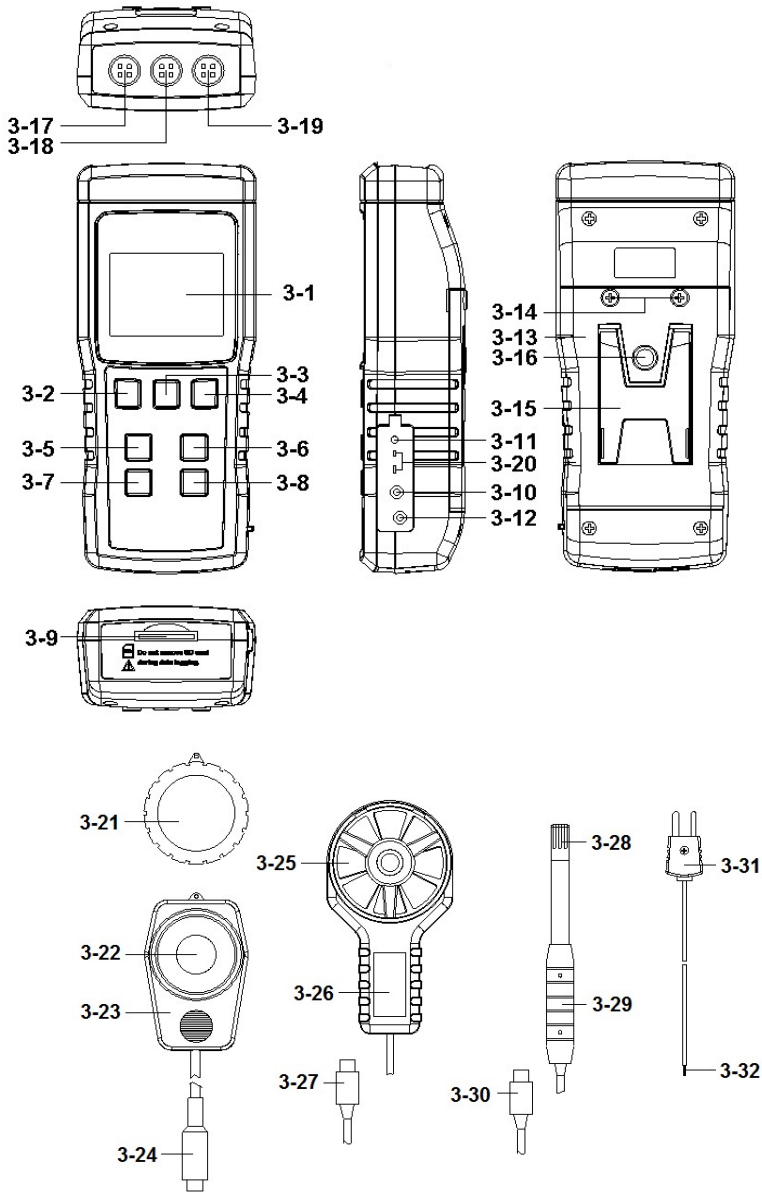

Fig. 1

- 3-1 Display
- 3-2 Power Button (LCD Brightness adjustment)
- 3-3 Hold Button
- 3-4 REC Button
- 3-5 ▲ Button (Unit Button)
- 3-6 ▼ Button (Function Button)
- 3-7 TIME Button (SET Button)
- 3-8 ENTER (LOG Button)
- 3-9 SD card socket
- 3-10 RS-232 Output Terminal
- 3-11 Reset Button
- 3-12 DC 9V Power Adapter Input Socket
- 3-13 Battery Compartment/Cover
- 3-14 Battery Cover Screws
- 3-15 Stand
- 3-16 Tripod Fix Nut
- 3-17 Light Probe input socket
- 3-18 Humidity/Temp. Probe input socket
- 3-19 Anemometer Probe input socket
- 3-20 Thermocouple Probe input socket
- 3-21 Light sensor Cover
- 3-22 Light sensor
- 3-23 Light Probe hand
- 3-24 Light Probe plug
- 3-25 Anemometer sensor
- 3-26 Anemometer Probe hand
- 3-27 Anemometer Probe plug
- 3-28 Humidity/Temp. sensor
- 3-29 Humidity/Temp. Probe hand
- 3-30 Humidity/Temp. Probe plug
- 3-31 Thermocouple Probe plug
- 3-32 Thermocouple Probe sensor

4. MEASURING PROCEDURE

4-1 Function selection

- 1) Turn on the meter by pressing the " Power Button "
(3-2, Fig. 1) momentarily.

* Pressing the " Power Button " (3-2, Fig. 1)
continuously and > 2 seconds again will turn off the
meter.

- 2) The meter Simultaneously can measurement five function screen.
 - a. Humidity/Temp + Air velocity/Temp. + Light meter
+ K or J Thermometer
 - b. Humidity + Temp + DEW + WET
 - c. Air velocity + Temp + FLOW
 - d. Light meter
 - e. Type K or J Thermometer

Pressing the " Function Button " (3-6, Fig. 1)
continuously (not release the button), the Display
will show the following text in sequence :

**(RH/Temp+AM/Temp+LUX+K)-->(RH+Temp+DEW+WET)--->
(AM+Temp+FLOW)--->(LUX)--->(K or J Thermometer)**

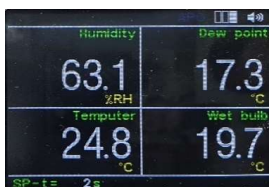
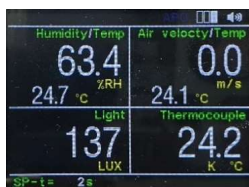

when the screen show the desired Function ,
just release the " Function Button " (3-6, Fig. 1), the meter will
show this function measure screen with default.

***Although select single function measure screen, but other
function measure , still being executed.**

4-2 Air velocity/Temp. measurement

- 1) Function select to " Air velocity/Temp. " measurement.
- 2) Plug the " Probe Plug " (3-27, Fig. 1) into the " Probe Input Socket " (3-19, Fig. 1).
Power on the meter by pressing the " Power Button " (3-2, Fig. 1) once,
- 3) Hold the Probe by hand and let the " Anemometer sensor " (3-25, Fig. 1) face against the measuring air flow source, then the Display (3-1, Fig. 1) will show air velocity directly. At the same time, the lower Display will show the air temperature value and air flow.

Change the Air velocity unit

Air velocity unit are :

m/S, FPM (Ft/min), Km/h, Knots, mph (Mile/h)

If intend to change the Air velocity unit, select to the Air velocity function only, then press the "Unit Button " (3-5 Fig.1) continuously, the unit will change from m/S to Km/h, mph, Knot, FPM in sequence, until the desired unit is present on the Display release the " Unit Button ", the select unit will save into the memory with default.

Change the Air Flow unit

*The meter is defaulted to " Air Flow CMM ".
If intend to select the " Air Flow CFM" with default , please refer chapter 7-9 (page 24).*

4-3 Humidity and Temperature measurement

- 1) Function select to " Humidity/Temp. " measurement.
Plug the " Probe Plug " (3-30, Fig. 1) into the " Probe Input Socket " (3-18, Fig. 1).
- 2) Power on the meter by pressing the " Power Button " (3-2, Fig. 1), the LCD shows the unit " %RH " & " °C or °F " at the same time and measured value will show on the display (upper display is Humidity value, the lower display is the temperature value ,Upper right show Dew value, bottom right show Wet value) .

Change the temperature unit (°C, °F)

If intend to change the Temp. display unit, select to the Humidity and Temperature measurement function only, then press the "Unit Button " (3-5 Fig.1) continuously, the unit will change from " °C " to " °F " sequence, until the desired unit is present on the Display release the " Unit Button ", the select unit will save into the memory with default.

4-4 Type K/J thermometer

- 1) Function select to " Type K/J thermometer "
- 2) Plug the Thermocouple Temp. Probe (Type K Temp. probe or Type J Temp. probe, optional) Plug(3-31 Fig.1) into " Type K/J Probe Input Socket " (3-20, Fig. 1)
The Display will show the measuring value that sensing from the Temp. probe.
- 3) If the Display show the indicator " K ", it is ready for Type K thermometer.
If the Display show the indicator " J ", it is ready for Type J thermometer.

Change the K type or the J type

*The meter is defaulted to " Type K thermometer ".
If intend to select the " Type J thermometer with default , please refer chapter 7-6 (page 23).*

Change the temperature unit (°C, °F)

If intend to change the Temp. display unit, select to the Type K/J Thermometer function only, then press the "Unit Button " (3-5, Fig.1) continuously, the unit will change from " °C " to " °F " sequence, until the desired unit is present on the Display release the " Unit Button ", the select unit will save into the memory with default.

4-5 Light Meter measurement

- 1) Function select to " Light meter " measurement.
- 2) Plug the " Probe Plug " (3-24, Fig. 1) into the " Probe Input Socket " (3-17, Fig. 1).
Power on the meter by pressing the " Power Button " (3-2, Fig. 1) once,
- 3) Hold the Probe by hand and let the " Light sensor " (3-22, Fig. 1) face against the measurement light source, the Display (3-1, Fig. 1) will show the light measurement value.

Unit change for light measurement

If intend to change the Light unit (LUX, Ft-cd), At the light mode only, press the Unit Button " (3-5, Fig.1) continuously, the unit will change from LUX, Ft-cd in sequence, until the desired unit is present on the Display release the Unit Button , the select unit will save into the memory with default.

Zero adjustment

During the Light measurement, use the light sensor cover (3-21 Fig.1) blank the Light Sensor (3-22, Fig. 1) completely, if the Display is not show zero value, together press the " ▲ Button " (3-5, Fig. 1) & " ▼ Button " (3-6, Fig. 1) > 3 seconds, Display will show the zero value.

4-6 Data Hold

During the measurement, press the " Hold Button " (3-3, Fig. 1) once will hold the measured value & the LCD will display a " HOLD " symbol.

Press the " Hold Button " once again will release the data hold function.

4-7 Data Record (Max., Min. reading)

- 1) The data record function records the maximum and minimum readings. Press the " REC Button " (3-4, Fig. 1) once to start the Data Record function and there will be a " REC " symbol on the display.
- 2) With the " REC " symbol on the display :
 - a) Press the " REC Button " (3-4, Fig. 1) once, the " REC MAX " symbol along with the maximum value will appear on the display.
If intend to delete the maximum value, just press the " Hold Button " (3-3, Fig. 1) once, then the display will show the " REC " symbol only & execute the memory function continuously.

- b) Press the " REC Button " (3-4, Fig. 1) again, the " REC MIN " symbol along with the minimum value will appear on the display.
If intend to delete the minimum value, just press the " Hold Button " (3-3, Fig. 1) once, then the display will show the " REC. " symbol only & execute the memory function continuously.
- c) To exit the memory record function, just press the " REC " button for 2 seconds at least. The display will revert to the current reading.

4-8 LCD brightness select

Depending on the brightness of the environment, can use the "Backlight Button " (3-2, Fig. 1) select from 3rd-order LCD Backlight brightness.

5. DATALOGGER

5-1 Preparation before execute datalogger function

a. Insert the SD card

Prepare a " SD memory card " (1 G to 16 G, optional), insert the SD card into the " SD card socket " (3-9, Fig. 1). The front panel of the SD card should face against the down case.

b. SD card Format

If SD card just the first time use into the meter, it recommend to make the " SD card Format " at first. , please refer chapter 7-8 (page 24).

c. Time setting

If the meter is used at first time, it should to adjust the clock time exactly, please refer chapter 7-1 (page 21).

d. Decimal format setting

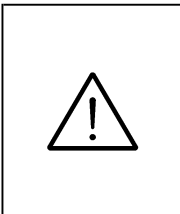

The numerical data structure of SD card is default used the " ." as the decimal, for example "20.6" "1000.53" . But in certain countries (Europe ...) is used the " , " as the decimal point, for example " 20, 6 " "1000,53". Under such situation, it should change the Decimal character at first, details of setting the Decimal point, refer to Chapter 7-5, page 22.

5-2 Auto Datalogger (Set sampling time ≥ 1 second)

a. Start the datalogger

Press the " LoggerButton (3-8, Fig. 1) > 2 Sec. , the LCD will show the text " LOGGER ", and flashing , at the same time the measuring data along the time information will be saved into the memory circuit.

Remark :

- * *How to set the sampling time, refer to Chapter 7-4, page 22.*
- * *How to set the beeper sound is enable, refer to Chapter 7-3, page 22.*

b. Pause the datalogger

During execute the Datalogger function , if press the " Logger Button " (3-8, Fig. 1) once will pause the Datalogger function (stop to save the measuring data into the memory circuit temporally). In the same time the text of " LOGGER " will stop flashing.

Remark :

If press the " Logger Button " (3-8, Fig. 1) once again will execute the Datalogger again, the text of " LOGGER " will flashing .

c. Finish the Datalogger

During pause the Datalogger, press the " Logger Button " (3-8, Fig. 1) continuously at least two seconds, the " Logger " indication will be disappeared and finish the Datalogger.

5-3 Manual Datalogger (Set sampling time = 0 second)

a. Set sampling time is to 0 second

Press the " Logger Button (3-8, Fig. 1) >2 Sec. , the LCD will show the text " Logger ", then press the " Logger Button " (3-8, Fig. 1) once, the " LOGGER " will flashing once and Beeper will sound once, at the same time the measuring data along the time information will be saved into the memory circuit. The lower Display will show the Position (Location) no. and saved into the SD card too.

Remark :

During execute the Manual Datalogger,

It can use the " ▲ Button " (3-5, Fig. 1) or "

▼ Button " (3-6, Fig. 1) to set the measuring position (1 to 99, for example room 1 to room 99) to identify the measurement location , the lower Display will show P x (x = 1 to 99).

b. Finish the Datalogger

Press the " Logger Button " (3-8, Fig. 1) continuously at least two seconds, the " Logger " indication will be disappeared and finish the Datalogger.

5-4 Check time & Sample information

During the normal measurement (not execute the Datalogger), If press " Time Button " (3-7, Fig. 1) once , the TFT LCD display will present the time information of Year, Month/Date, Hour/Minute & Sampling time information .

5-5 SD Card Data structure

- 1) When the first time, the SD card is used into the meter, the SD card will generate a folder :

EMC01

- 2) If the first time to execute the Datalogger, under the route EMC01\, will generate a new file name EMC01001.XLS.
After exist the Datalogger, then execute again, the data will save to the EMC01001.XLS until Data row reach to 30,000 rows, then will generate a new file, for example EMC01002.XLS
- 3) Under the folder EMC01\, if the total files more than 99 files, will generate a new route, such as EMC02\
- 4) The file's route structure :

```
EMC01\  
    EMC01001.XLS  
    EMC01002.XLS  
  
    .....  
    EMC01099.XLS  
EMC02\  
    EMC02001.XLS  
    EMC02002.XLS  
  
    .....  
    EMC02099.XLS  
EMCXX\  
    .....
```

Remark : *XX : Max. value is 10.*

6. Saving data from the SD card to the computer (EXCEL software)

- 1) After execute the Data Logger function, take away the SD card out from the " SD card socket " (3-9, Fig. 1).
- 2) Plug in the SD card into the Computer's SD card slot (if your computer build in this installation) or insert the SD card into the " SD card adapter ". then connect the " SD card adapter " into the computer.
- 3) Power ON the computer and run the " EXCEL software ". Down load the saving data file (for example the file name : EMC01001.XLS, EMC01002.XLS) from the SD card to the computer. The saving data will present into the EXCEL software screen (for example as following EXCEL data screens) , then user can use those EXCEL data to make the further Data or Graphic analysis usefully.

EXCEL data screen (for example)

	A	B	C	D	E	F	G	H	I	J	K	L	M	N	O	P	Q	R	S	T	U	
1	Place	Date	Time	Value	Unit	Value	Unit	Value	Unit	Value	Unit	Value	Unit	Value	Unit	Value	Unit	Value	Unit	Value	Unit	
2	3	2017/1/1	00:01:28	1.9	ml/s	23.3	Temp C	0.114	CMM	52.2	%RH	25.6	Temp C	15	DP C	18.6	WET C	23.7	K	Temp C	245	LUX
3	4	2017/1/1	00:01:30	1.9	ml/s	23.3	Temp C	0.114	CMM	52.2	%RH	25.6	Temp C	15	DP C	18.6	WET C	23.6	K	Temp C	345	LUX
4	5	2017/1/1	00:01:32	1.8	ml/s	23.3	Temp C	0.108	CMM	64.1	%RH	25.7	Temp C	18.4	DP C	19.2	WET C	23.6	K	Temp C	347	LUX
5	6	2017/1/1	00:01:34	1.8	ml/s	23.3	Temp C	0.108	CMM	57.8	%RH	25.7	Temp C	16.7	DP C	19.9	WET C	23.6	K	Temp C	347	LUX
6	7	2017/1/1	00:01:36	1.7	ml/s	23.3	Temp C	0.102	CMM	54.3	%RH	25.7	Temp C	15.7	DP C	19.4	WET C	23.7	K	Temp C	347	LUX
7	8	2017/1/1	00:01:38	1.8	ml/s	23.4	Temp C	0.108	CMM	53.5	%RH	25.7	Temp C	15.5	DP C	19.1	WET C	23.7	K	Temp C	346	LUX
8	9	2017/1/1	00:01:40	1.8	ml/s	23.4	Temp C	0.108	CMM	52.7	%RH	25.7	Temp C	15.3	DP C	18.8	WET C	23.7	K	Temp C	346	LUX
9	10	2017/1/1	00:01:42	1.8	ml/s	23.4	Temp C	0.108	CMM	52.5	%RH	25.6	Temp C	15.1	DP C	18.7	WET C	23.7	K	Temp C	371	LUX
10	11	2017/1/1	00:01:44	1.6	ml/s	23.4	Temp C	0.096	CMM	52.5	%RH	25.6	Temp C	15.1	DP C	18.7	WET C	23.7	K	Temp C	398	LUX
11	12	2017/1/1	00:01:46	1.6	ml/s	23.4	Temp C	0.096	CMM	52.5	%RH	25.6	Temp C	15.2	DP C	18.7	WET C	23.7	K	Temp C	435	LUX
12	13	2017/1/1	00:01:48	1.5	ml/s	23.4	Temp C	0.09	CMM	52.6	%RH	25.6	Temp C	15.1	DP C	18.7	WET C	23.7	K	Temp C	428	LUX
13	14	2017/1/1	00:01:50	1.5	ml/s	23.4	Temp C	0.09	CMM	52.6	%RH	25.6	Temp C	15.2	DP C	18.7	WET C	23.8	K	Temp C	459	LUX
14	15	2017/1/1	00:01:52	1.5	ml/s	23.4	Temp C	0.09	CMM	52.6	%RH	25.6	Temp C	15.1	DP C	18.7	WET C	23.8	K	Temp C	490	LUX
15	16	2017/1/1	00:01:54	1.5	ml/s	23.4	Temp C	0.09	CMM	52.7	%RH	25.6	Temp C	15.2	DP C	18.7	WET C	23.8	K	Temp C	1300	LUX
16	17	2017/1/1	00:01:56	1.5	ml/s	23.4	Temp C	0.09	CMM	52.6	%RH	25.6	Temp C	15.1	DP C	18.7	WET C	23.7	K	Temp C	2240	LUX
17	18	2017/1/1	00:01:58	1.5	ml/s	23.4	Temp C	0.09	CMM	52.6	%RH	25.6	Temp C	15.1	DP C	18.7	WET C	23.7	K	Temp C	177	LUX
18	19	2017/1/1	00:02:00	1.5	ml/s	23.4	Temp C	0.09	CMM	52.6	%RH	25.6	Temp C	15.1	DP C	18.7	WET C	23.7	K	Temp C	182	LUX
19	20	2017/1/1	00:02:02	1.5	ml/s	23.4	Temp C	0.09	CMM	52.7	%RH	25.6	Temp C	15.2	DP C	18.7	WET C	23.8	K	Temp C	186	LUX
20	21	2017/1/1	00:02:04	1.5	ml/s	23.4	Temp C	0.09	CMM	52.6	%RH	25.6	Temp C	15.1	DP C	18.7	WET C	23.9	K	Temp C	84	LUX
21	22	2017/1/1	00:02:06	1.5	ml/s	23.4	Temp C	0.09	CMM	52.6	%RH	25.6	Temp C	15.1	DP C	18.7	WET C	23.8	K	Temp C	376	LUX
22	23	2017/1/1	00:02:08	1.5	ml/s	23.4	Temp C	0.09	CMM	52.7	%RH	25.6	Temp C	15.2	DP C	18.7	WET C	23.8	K	Temp C	382	LUX
23	24	2017/1/1	00:02:10	1.5	ml/s	23.4	Temp C	0.09	CMM	52.6	%RH	25.6	Temp C	15.1	DP C	18.7	WET C	23.8	K	Temp C	384	LUX
24	25	2017/1/1	00:02:12	1.5	ml/s	23.4	Temp C	0.09	CMM	52.6	%RH	25.6	Temp C	15.1	DP C	18.7	WET C	23.8	K	Temp C	383	LUX

EXCEL graphic screen (for example)



7. ADVANCED SETTING

Under do not execute the Datalogger function, press the " SET Button " (3-7, Fig. 1) continuously at least two seconds will enter the " Advanced Setting " mode. then press the " ▲(3-5, Fig. 1)" or "▼(3-6, Fig. 1)"key ,to select will chang setting mode (text will turn yellow color),in sequence to select the eight main function, as follows:

- | | |
|-----------------|--|
| CLOCK TIME | Set clock time (Year/Month/Date, Hour/Minute/Second) |
| AUTO POWER OFF | Auto power OFF management |
| BEEPER SOUND | Set beeper sound ON/OFF |
| SAMPLE TIME | Set sampling time (Second) |
| DECIMAL POINT | Set SD card Decimal character |
| K/J SELECT | Select the Thermometer to Type K or Type J |
| AREA DIMENSION | Set area dimension |
| SD FORMAT | SD memory card Format |
| Air Flow SELECT | Select the Air Flow to CMM or CFM |

Remark :

During execute the " Advanced Setting " function, if press " Power Button " (3-2, Fig. 1) once will exit the " Advanced Setting " function, the LCD will return to normal screen.

7-1 Set clock time (Year/Month/Date, Hour/Minute/ Second)

When the lower display show " CLOCK TIME "

- 1) Press the " Enter Button " (3-8, Fig. 1) once, Use the " ▲ Button " (3-5, Fig. 1) or " ▼ Button " (3-6, Fig. 1) to adjust the value (Setting start from Year value). After the desired value is set, press the " Time Button " (3-7, Fig. 1) once will going to next value adjustment (for example, first setting value is Year then next to adjust Month, Date, Hour, Minute, Second value).
- 2) After set all the time value (Year, Month, Date, Hour, Minute, Second), press the " ENTER Button " (3-8, Fig. 1) once ,will save and Back to " Advanced Setting screen " .

Remark :

After the time value is setting, the internal clock will run precisely even Power off if the battery is under normal condition (No low battery power).

7-2 Auto power OFF management

When the lower display show " AUTO POWER OFF "

- 1) Use the " ▲ Button " (3-5, Fig. 1) or " ▼ Button " (3-6, Fig. 1) to select the display text to " YES " or " NO " .

YES - Auto Power Off management will enable.

NO - Auto Power Off management will disable.

- 2) After select the upper text to " YES " or " NO ", press the " Enter Button " (3-8, Fig. 1) will save the setting function with default and Back to " Advanced Setting screen " .

7-3 Set beeper sound ON/OFF

When the lower display show " BEEPER SOUND "

- 1) Use the " ▲ Button " (3-5, Fig. 1) or " ▼ Button " (3-6, Fig. 1) to select the display text to " YES " or " NO " .

YES - Meter's beep sound will be ON with default.

**NO - Meter's beep sound will be OFF with default.
is power ON.**

- 2) After select the upper text to " YES " or " NO ", press the " Enter Button " (3-8, Fig. 1) will save the setting function with default and Back to " Advanced Setting screen " .

7-4 Set sampling time (Seconds)

When the lower display show " SAMPLE TIME "

- 1) Use the " ▲ Button " (3-5, Fig. 1) or " ▼ Button " (3-6, Fig. 1) to adjust the value (1, 2, 5, 10, 30,60, 120, 300, 600, 1800,3600 seconds).
- 2) After the Sampling value is selected, press the " Enter Button " (3-8, Fig. 1) will save the setting function with default and Back to " Advanced Setting screen " .

7-5 Decimal point of SD card setting

The numerical data structure of SD card is default used the " ." as the decimal, for example "20.6" "1000.53" . But in certain countries (Europe ...) is used the " , " as the decimal point, for example " 20,6 " "1000,53" . Under such situation, it should change the Decimal character at first.

When the lower display show " DECIMAL POINT "

- 1) Use the " ▲ Button " (3-5, Fig. 1) or " ▼ Button " (3-6, Fig. 1) to select the display text to " USA " or " EURO ".

USA - Use " . " as the Decimal point with default.

EURO - Use " , " as the Decimal point with default.

- 2) After select the upper text to " USA " or " EURO ", press the " Enter Button " (3-8, Fig. 1) will save the setting function with default and Back to " Advanced Setting screen ".

7-6 Select the Thermometer to Type K or Type J

When the lower display show " K/J SELECT "

- 1) Use the " ▲ Button " (3-5, Fig. 1) or " ▼ Button " (3-6, Fig. 1) to select the Display text to " K " or " J ".

K - Type K thermometer

J - Type J thermometer

- 2) After Display unit is selected to " K " or " J ", press the " Enter Button " (3-8, Fig. 1) will save the setting function with default and Back to " Advanced Setting screen ".

7-7 Set the area size of Air flow measurement

When the lower display show " AREA DIMENSION "

At this mode and press the ENTER key, the AREA DIMENSION word and the current set area (as shown below) will be displayed. At this time, the TIME button switches the set position (from right to left). After selecting, press ▲ or ▼ key to adjust the value. Press ENTER when the setting is completed, it will save and return to the main menu.

7-8 SD memory card Format

When the lower display show " SD FORMAT "

- 1) Use the " ▲ Button " (3-5, Fig. 1) or " ▼ Button " (3-6, Fig. 1) to select the display text to " YES " or " NO ".

YES - Intend to format the SD memory card

NO - Not execute the SD memory card format

- 2) If select the upper to " yES ", press the " Enter Button " (3-8, Fig. 1) once again, the Display will show text " SURE " to confirm again, if make sure to do the SD memory card format, then press " Enter Button " once will format the SD memory clear all the existing data that already saving into the SD card.

7-9 Air Flow SELECT

When the lower display show " Air Flow SELECT "

- 1) Use the " ▲ Button " (3-5, Fig. 1) or " ▼ Button " (3-6, Fig. 1) to select the display text to " CMM " or " CFM ".

CMM - Air flow mrasurement unit is Metric unit and default.

CFM- Air flow mrasurement unit is Imperial unit and default.

- 2) After select the upper text to " CMM " or " CFM ", press the " Enter Button " (3-8, Fig. 1) will save the setting function with default and Back to " Advanced Setting screen ".

8. POWER SUPPLY from DC ADAPTER

The meter also can supply the power supply from the DC 9V Power Adapter (optional). Insert the plug of Power Adapter into " DC 9V Power Adapter Input Socket " (3-12, Fig. 1).

9. BATTERY REPLACEMENT

- 1) When the left corner of LCD display show "  ", it is necessary to replace the battery. However, in-spec. measurement may still be made for several hours after low battery indicator appears before the instrument become inaccurate.
- 2) Loose the screws of the " Battery Cover " (3-13, Fig. 1) and take away the " Battery Cover " from the instrument and remove the battery.
- 3) Replace with DC 1.5 V battery (UM3, AA, Alkaline/heavy duty) x 6 PCs, and reinstate the cover.
- 4) Make sure the battery cover is secured after changing the battery.

10. SYSTEM RESET

If the meter happen the troubles such as :

CPU system is hold (for example, the key button can not be operated...).

Then make the system RESET will fix the problem.
The system RESET procedures will be either following method :

During the power on, use a pin to press the " Reset Button " (3-11, Fig. 1) once a while will reset the circuit system.

11. RS232 PC SERIAL INTERFACE

The instrument has RS232 PC serial interface via a 3.5 mm terminal (3-10, Fig. 1).

The data output is a 16 digit stream which can be utilized for user's specific application.

A RS232 lead with the following connection will be required to link the instrument with the PC serial port.

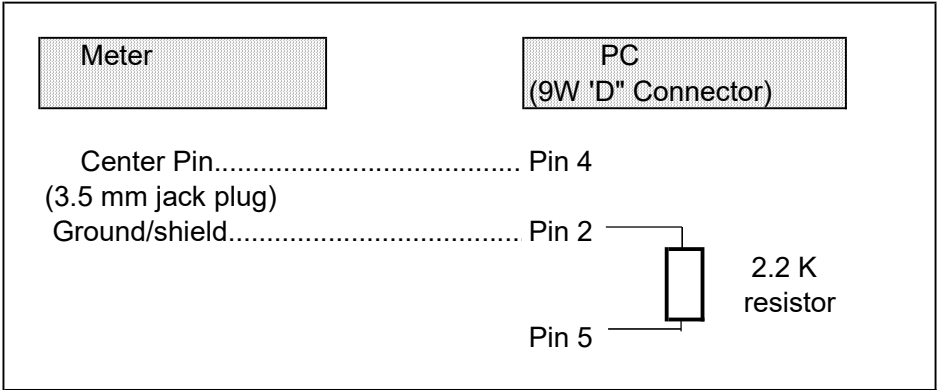

The 16 digits data stream will be displayed in the following format :

D15 D14 D13 D12 D11 D10 D9 D8 D7 D6 D5 D4 D3 D2 D1 D0

Each digit indicates the following status :

D0	End Word
D1 & D8	Display reading, D1 = LSD, D8 = MSD For example : If the display reading is 1234, then D8 to D1 is : 00001234
D9	Decimal Point(DP), position from right to the left 0 = No DP, 1= 1 DP, 2 = 2 DP, 3 = 3 DP
D10	Polarity 0 = Positive 1 = Negative

D11 & D12	Annunciator for Display		
	°C = 01	Knot = 09	mile/h = 12
	°F = 02	Km/h = 10	m/S = 08
	ft/min = 11	LUX = 15	Ft-cd = 16
	% RH = 04	CMM = 84	CFM = 85
D13	When send the upper display data = 1 When send the lower display data = 2		
D14	4		
D15	Start Word		

RS232 FORMAT : 9600, N, 8, 1

Baud rate	9600
Parity	No parity
Data bit no.	8 Data bits
Stop bit	1 Stop bit

12. Optional Type K Temp. probe

(Type K) TP-01	<ul style="list-style-type: none"> * Max. short-tern operating Temperature: 300 °C (572 °F). * It is an ultra fast response naked-bead thermocouple suitable for many general purpose application.
Thermocouple Probe (Type K), TP-02A	<ul style="list-style-type: none"> * Measure Range: -50 °C to 900 °C, -50 °F to 1650 °F. * Dimension: 10cm tube, 3.2mm Dia.
Thermocouple Probe (Type K), TP-03	<ul style="list-style-type: none"> * Measure Range: -50 °C to 1200 °C, -50 °F to 2200 °F. * Dimension: 10cm tube, 8mm Dia.
Surface Probe (Type K), TP-04	<ul style="list-style-type: none"> * Measure Range: -50 °C to 400 °C, -50 °F to 752 °F. * Size : Temp. sensing head - 15 mm Dia. Probe length - 120 mm.

13. PATENT

The meter (SD card structure) already get patent in following countries :

Germany	Nr. 20 2008 016 337.4
JAPAN	3151214
CHINA	ZL 2008 2 0189918.5 ZL 2008 2 0189917.0