

*10 Amperes max. test current*

# Micro-Ohm Meter

Model : MO-2014



Your purchase of this Micro-Ohm METER marks a step forward for you into the field of precision measurement.

Although this Micro-Ohm METER is a complex and delicate instrument, its durable structure will allow many years of use if proper operating techniques are developed. Please read the following instructions carefully and always keep this manual within easy reach.

**OPERATION MANUAL**

# TABLE OF CONTENTS

1. FEATURES.....	1
2. SPECIFICATIONS.....	1
2-1 General Specifications.....	1
2-2 Electrical Specifications.....	2
3. FRONT / REAR PANEL DESCRIPTION.....	3
4. BASIC 4 WIRES MEASURING PRINCIPLE.....	4
5. PRECAUTION & PREPARATIONS FOR MEASUREMENT.....	5
6. MEASURING PROCEDURES.....	5
6-1 Buttons instructions .....	5
6-2 Symbols & units of display.....	6
6-3 Resistance Measurement.....	6
7. HI / LO WARNING SETUP.....	7
8. CALCULATE CABLE / WIRE LENGTH.....	9
9. RS232 PC SERIAL INTERFACE.....	10
10. BATTERY REPLACEMENT.....	11

# 1. FEATURES

- \* 4 terminal devices for accurate measurement of very low resistance.
- \* Ideal for measuring the resistance of components precisely.
- \* Ideal for testing protective conductors, lightning conductors and welded points.
- \* Maximum test current is 10A ( 60000  $\mu\Omega$  range only ).
- \* Have two working mode , Resistive and Inductive mode, Normal is resistive mode.
- \* Good / Fail set-function for input quality control.
- \* Built-in in buzzer sound (GOOD STATUS) to assist the Q.C. judgment.
- \* Especial "CALCULATE" function to measure cable / wire length.
- \* Wide measuring range, 5  $\mu\Omega$  - 6K  $\Omega$  , 6 ranges.
- \* Large size and back-light LCM display, easy read-out.
- \* LSI circuit provides high accuracy, reliability and durability.
- \* Built-in over input protection.
- \* Durable bench type housing plastic case stand.

# 2. SPECIFICATIONS

## *2-1 General Specifications*

Test Range (Test Current)	60000 $\mu\Omega$ ( 10 A DC ) 600 m $\Omega$ ( 1 A DC ) 6000 m $\Omega$ ( 100 mA DC ) 60000 m $\Omega$ ( 10 mA DC ) 600 $\Omega$ ( 1 mA DC ) 6000 $\Omega$ ( 100 $\mu$ A DC )
Warning Setup	* Warning LCD Indicator * Buzzer
Operating Temp.	0 to 50 $^{\circ}$ C ( 32 to 122 $^{\circ}$ F ).
Operating Humidity	Less than 80 % R.H..
Power Supply	DC 1.5 V , AA (UM-3)Battery X 8 PCs . AC to DC 9V Power adapter .

Fuse protect	* 10 A / 250 V * Size : 6.3 X 32 mm dia..
Dimension	225 x 125 x 64 mm ( 8.86 x 4.92 x 2.52 inch)
Weight	Approx. 790 g ( 1.74 LB ).
Standard Accessories	4 wire with 2 Kelvin clips..... 1 pair Instruction Manual..... 1 PC AC/DC 9V power adapter..... 1 set
Optional Accessories	* USB cable, USB-01. * RS232 cable, UPCB-02. * Data Acquisition software, SW-U801-WIN., SW-E802. * SD card data recorder, DL-9602SD

### ***2-2 Electrical Specifications ( 23± 5 °C )***

Range	Resolution	Test current	Accuracy
60000 uΩ	1 uΩ	10 A	± ( 0.25 % + 25 d )
600 mΩ	10 uΩ	1 A	
6000 mΩ	100 uΩ	100 mA	
60000 mΩ	1000 uΩ	10 mA	
600 Ω	10 mΩ	1 mA	
6000 Ω	100 mΩ	100 uA	± ( 0.75 % + 3 d )
<i>@ The above accuracy is based on the reading value.</i>			
<i>@ Spec. tested under the environment RF Field Strength less than 3 V/M &amp; frequency less than the 30 MHz only.</i>			

Range	Open Circuit Voltage
60000 u Ω	Approx. DC 4.33 V
600 m Ω	Approx. DC 4.33 V
6000 mΩ	Approx. DC 4.33 V
60000 mΩ	Approx. DC 4.33 V
600 Ω	Approx. DC 4.33 V
6000 Ω	Approx. DC 4.33 V

### 3. FRONT/REAR PANEL DESCRIPTION

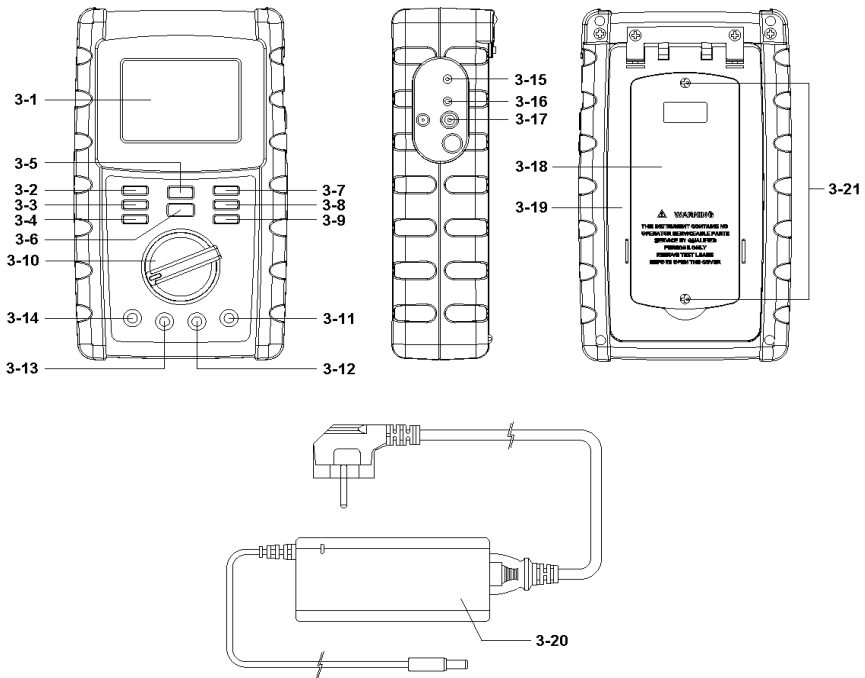

Fig. 1

- |                                  |                                          |
|----------------------------------|------------------------------------------|
| 3-1 Display                      | 3-11 Force Terminal "+"                  |
| 3-2 Backlight key button         | 3-12 Sense Terminal "+"                  |
| 3-3 Zero key button              | 3-13 Sense Terminal "-"                  |
| 3-4 SET / TEST key button        | 3-14 Force Terminal "-"                  |
| 3-5 HOLD key button              | 3-15 RS232 socket                        |
| 3-6 START / STOP key button      | 3-16 Reset button                        |
| 3-7 L / ▲ key button             | 3-17 DC 9V power adapter socket          |
| 3-8 Beep / ◀ key button          | 3-18 Battery Cover / Battery compartment |
| 3-9 COMP / ▼ key button          | 3-19 Stand                               |
| 3-10 Power / Range rotary switch | 3-20 AC/DC 9V power adapter              |
|                                  | 3-21 Battery cover screws                |

## 4. BASIC 4 WIRES MEASURING PRINCIPLE

*The DIGITAL MICRO-OHM METER is a precise, wide range, small resistance and high resolution measuring instrument. As for preventing any measuring errors, especially to avoid the influence of "LEAD STRAY RESISTANCE" or "TEST WIRE'S RESISTANCE", the meter is designed according to the following "4 WIRES MEASURING PRINCIPAL" to maintain the meter in high accuracy.*

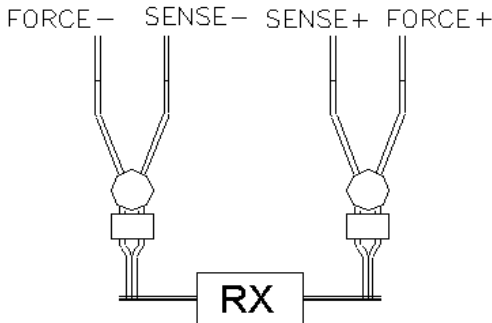

Fig. 2

- \* Please refer to 2-2 Electrical Specification ( page 2 ), each range exists fixed test current ( from 6000  $\Omega$  to 60000  $\mu\Omega$  .
- \* The fixed current flow through the unknown resistor Rx.
- \* From the terminal " Sense + " and " Sense - " can measure a voltage  $V_x = I_s \times R_x$ .
- \* According the  $V_x$  value, then meter can get the unknown resistance (Rx) values from following formula :

$$R_x = V_x / I_s$$

- \* The measured resistance value between "Sense +" and "Sense -" is not affected by any stray resistance of test wire.

## 5. PRECAUTION & PREPARATIONS FOR MEASUREMENT

- \* Please check carefully the meter's power supply is DC 9V power adapter before operating at 60000  $\mu\Omega$  range .
- \* It's prohibited to input voltage to the 4 wire input terminal ( Force +, Sense +, Sense -, Force - ) to prevent any internal circuit damage.

## 6. MEASURING PROCEDURES

### 6 -1 Buttons instructions

<b>Buttons</b>	<b>Function</b>
Backlight Button	Press this key to turn backlight on and off. * Used battery power. backlight will auto off after 30 second.
ZERO Button	When the display indicate few reading before measure .
SET/TEST Button	Press this key to do Hi / Lo limit setup. Press this key return to TEST status.
HOLD Button	Press this key to do data hold .
START/STOP Button	Press this key to starting measurement or stop.
L/▲ Button	Press this key to setting work mode (Resistive or Inductive). Press this key to adjust up value.
BEEP/ ◀ Button	Press this key to open / close buzzer function. * Beep function available for "COMP function". Press this key to select digit unit.
COMP / ▼ Button	Press this key to start "GOOD , FAIL " status judgment. Press this key to adjust down value.

### **6 -2 Symbols & units of display**

<b>Symbol &amp; Unit</b>	<b>Function</b>
$\mu\Omega$ , $m\Omega$ , $\Omega$	Ohm unit
·)))	Appears on the "BEEP" function have started.
HOLD	Appears on the"HOLD" function have started.
GOOD	It is pass Q.C. Appears on finished compare operate.
FAIL	It is higher or lower than maximum or minimum acceptance value . Appears on finished compare operate.
COMP	Appears on the"COMPARE" function.
L	Appears on the"INDUCTIVE" mode.
H i	Appears to showing H I limit.
Lo	Appears to showing LO limit.

### **6 -3 Resistance Measurement**

- 1) Power on the instrument by rotate the "Power / Range rotary switch" ( 3-10, Fig. 1 ) to exit the " OFF " position and then select measuring range from 60000  $\mu\Omega$  to 6000  $\Omega$  according to your requirement.

**Note :**

- \* **Always select the highest range ( 6000  $\Omega$  ) if you don't know the resistance value of the resistor and then select lower range in sequence.**
- \* **At 60000  $\mu\Omega$  ( 10A ) must use DC 9V adapter from socket ( 3-17, Fig. 1 ).**
- \* **Over range LCD shows " ----- ".**
- \* **Can't measure the resistance value, LCD will show 0.0, 0.00 or 0.**



- 2) Connect the
  - \* Red cable ( with white O ring marker ) to " Force + " terminal ( 3-11, Fig. 1 )
  - \* Red cable ( no white O ring marker ) to " Sense + " terminal ( 3-12, Fig. 1 )
  - \* Black cable ( with white O ring marker ) to " Force - " terminal ( 3-14, Fig. 1 )
  - \* Black cable ( no white O ring marker ) to " Sense - " terminal ( 3-13, Fig. 1 )
- 3) Connect the 2 Kelvin clips as following Fig. 2 to measure the unknown resistance.
- 4) Press the "START / STOP" key ( 3-6, Fig. 1 ) will start measure the unknown device.  
Press once again will stop measure function and froze the result at LCM.
- 5) When your tested material has inductive, you can press " L/▲ " key ( 3-7, Fig. 1 ) for change to inductor mode ( at 600 mΩ and 60000 uΩ range ) , Display will showing " L " mark. normal is resistor mode.

## 7. Hi/Lo WARNING SETUP

This instrument has Hi, Lo warning value setup function and a buzzer which are specially designed for quality control.

Primary to press the " SET / TEST " ( 3-4, Fig. 1 ) button enter setting mode.

### 1) Hi warning value setup

The last digit should flash at " Hi warning value " on the display . Then press " L / ▲ " buttons ( 3-7, Fig. 1 ) to increase or " COMP / ▼ " buttons ( 3-9, Fig. 1 ) to decrease digit that you want to alter large value,

press the " BEEP / ◀ " buttons (3-8 , Fig. 1) set warning value , When user to move 1st digit unit to next digit unit (10th, 100th. 1000th).

**\* Hypothesize display be set at 180.00 .**

2) **Lo warning value setup**

Finished (1) procedure then press the " SET / TEST " button ( 3-4, Fig. 1 ) again, The last digit should flash at " Lo warning value " on the display . Other operate way same above explain.

**\* Hypothesize display be set at 179.00 .**

3) Finished (1)(2) procedure then press the " SET / TEST " button ( 3-4, Fig. 1 ) once . The function should return to TEST MODE and indicate measure value when clipping the resistor.

4) When measuring period press " COMP / ▼ " ( 3-9 , Fig. 1) button once, The display will show " GOOD " or " FAIL " symbol to inform be measure results.

For example

a. The value was readout 179.50 , The display should show " GOOD " symbol and buzzer sounds.( If buzzer function have been press on status, The buzzer sounds can to assist Q.C judgment ) The resistance value within the accuracy Pass the Q.C.

*\* Press " BEEP / ◀ " ( 3-8, Fig. 1) button once will start buzzer, press once again to disable " BEEP " function.*

b. The value was readout 180.10 or 178.60, The display should show " FAIL " symbol, The resistance value out of the accuracy.

## 8. CALCULATE CABLE/WIRE LENGTH

Before calculate cable length . You should sampling one unit length (meter or feet).

- 1)Primary to take one sample from a lot of cable or wire then to measure 1 meter or 1 feet in length..
- 2)Measure the unknown cable . wait a moment until the reading have been stable . Stop the measure action and hold the range.
- 3)Press " HOLD " button ( 3-5, Fig. 1 ) to release HOLD status.
- 4)Press " SET / TEST " button ( 3-4 , Fig.1) more than three seconds into sample unit mode.
- 5)Then press " L / ▲ " button ( 3-7 , Fig.1) or " COMP / ▼ " button( 3-9 , Fig.1) to select unit (meter or feet).
- 6)Press " START / STOP " button ( 3-6 , Fig.1) to sampling unit value.
- 7)Press " SET / TEST " button ( 3-4 , Fig.1) to save the value and showing the cable length .  
Now is already measurement unknown cable length.
- 8)Once press "SET / TEST" button ( 3-4 , Fig.1) more than 3 seconds. Will return to measure mode .

# 9. RS232 PC SERIAL INTERFACE

The instrument has RS232 PC serial interface via a 3.5 mm terminal ( 3-15, Fig. 1 ).

The data output is a 16 digit stream which can be utilized for user's specific application.

A RS232 lead with the following connection will be required to link the instrument with the PC serial port.

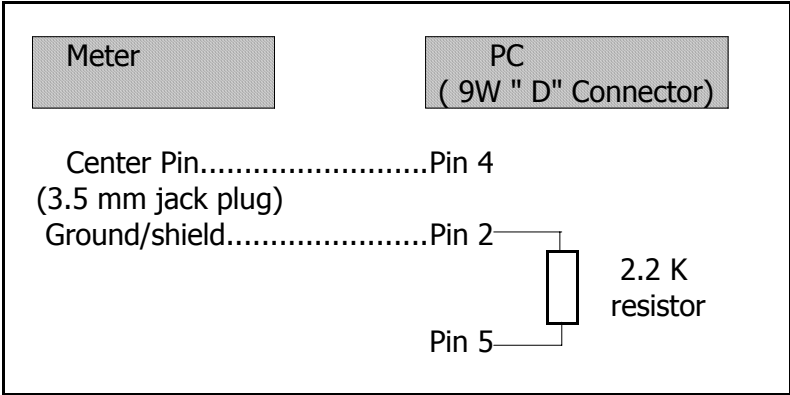

The 16 digits data stream will be displayed in the following format :

D15 D14 D13 D12 D11 D10 D9 D8 D7 D6 D5 D4 D3 D2 D1 D0

**Each digit indicates the following status :**

D15	Start Word
D14	4
D13	1

D12, D11	Annunciator for Display		
	$\Omega = 38$	$m\Omega = B1$	$\mu\Omega = F5$
D10	Polarity 0 = Positive 1 = Negative		
D9	Decimal Point(DP), position from right to the left 0 = No DP, 1= 1 DP, 2 = 2 DP, 3 = 3 DP		
D8 to D1	Display reading, D1 = LSD, D8 = MSD For example : If the display reading is 1234, then D8 to D1 is : 00001234		
D0	End Word,		

RS232 FORMAT : 9600, N, 8, 1

Baud rate	9600
Parity	No parity
Data bit no.	8 Data bits
Stop bit	1 Stop bit

## 10. BATTERY REPLACEMENT

- 1) When the left corner of LCD display show "  ", it is necessary to replace the battery. However, in-spec. measurement may still be made for several hours after low battery indicator appears before the instrument become inaccurate.
- 2) Loose the " Battery Cover Screws " ( 3-21, Fig. 1 ) and take away the " Battery Cover " ( 3-18, Fig. 1 ) from the instrument and remove the battery.
- 3) Replace with DC 1.5 V battery ( UM3, AA, Alkaline/heavy duty ) x 8 PCs, and reinstate the cover.
- 4) Make sure the battery cover is secured after changing the batteries